



XB-13001F

SUPER UNIVERSE BATTLESHIP



Set up 8 types of
SUPER UNIVERSE BATTLESHIP



F1

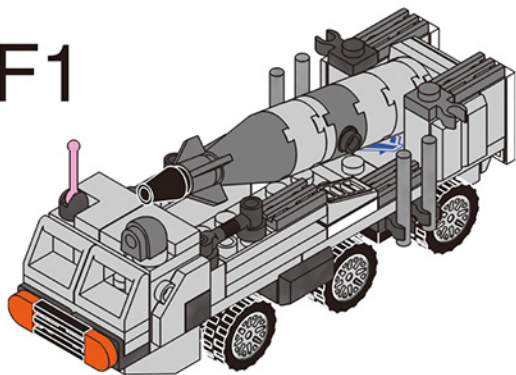

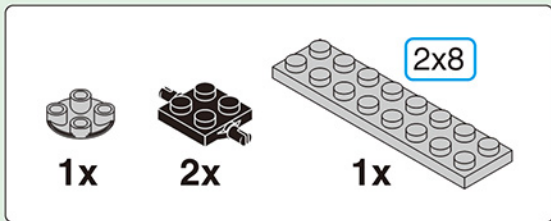

1

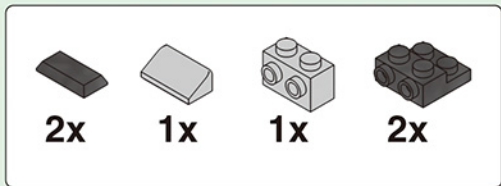
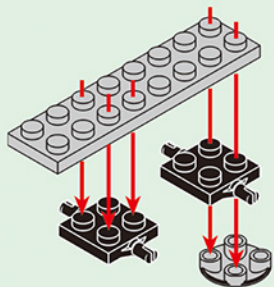

2

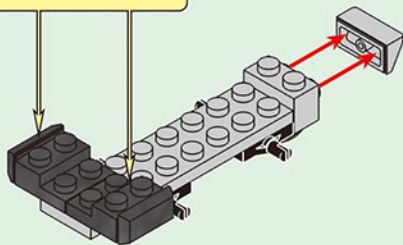
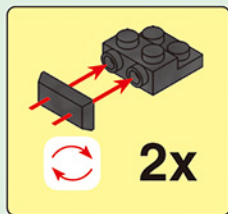

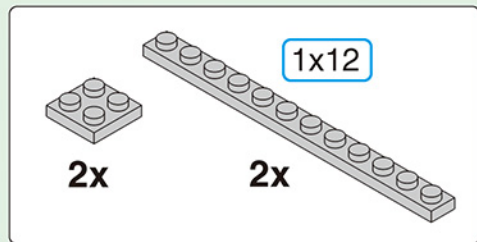

3

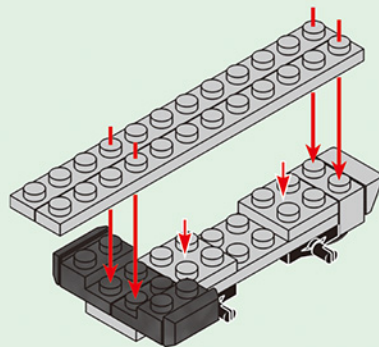

3

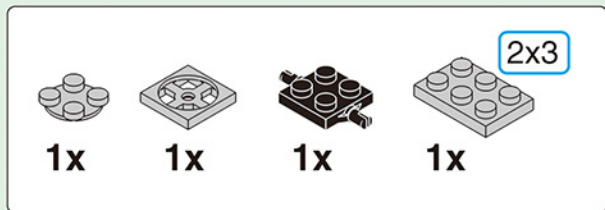

4

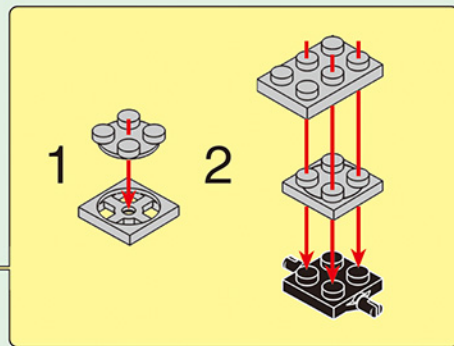
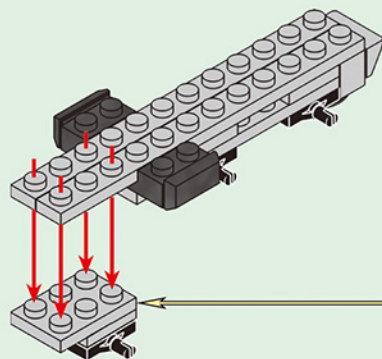

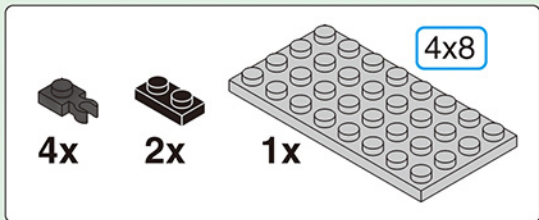

5

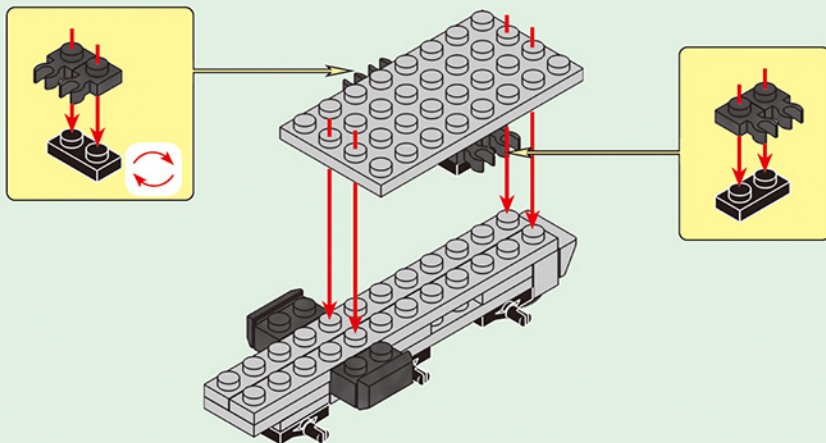

5

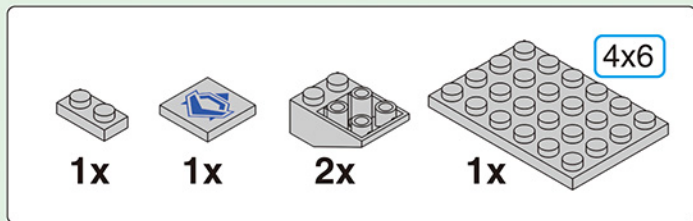

6

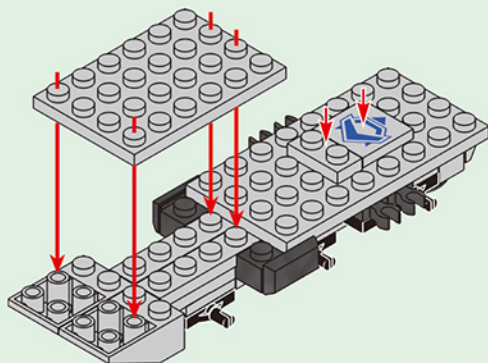

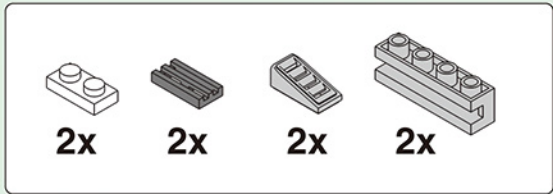

7

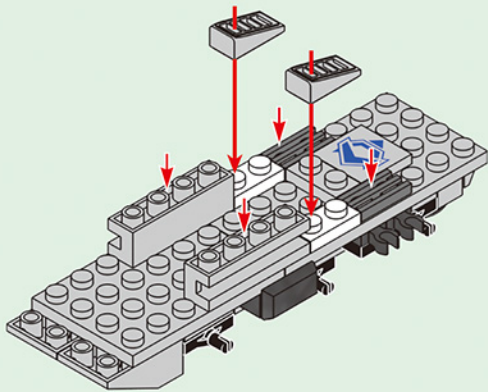

7

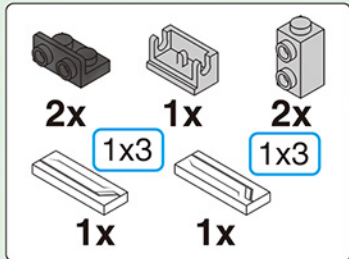

8

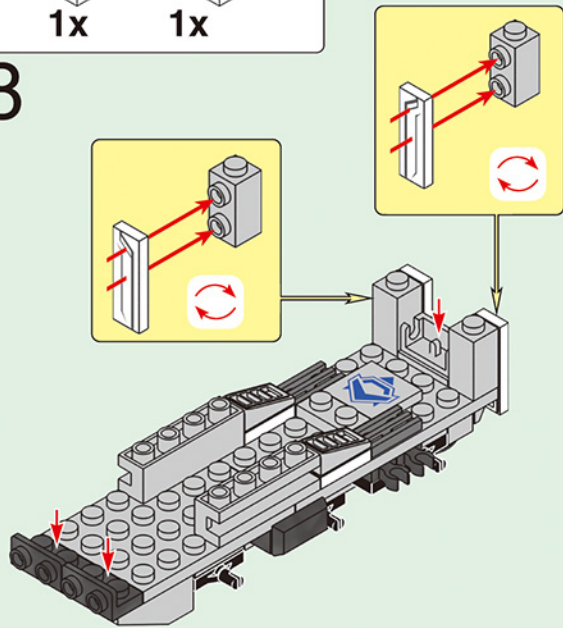

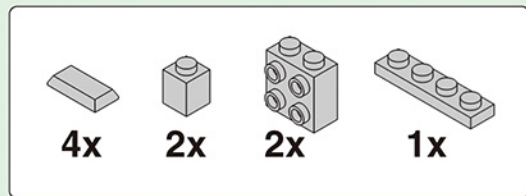

9

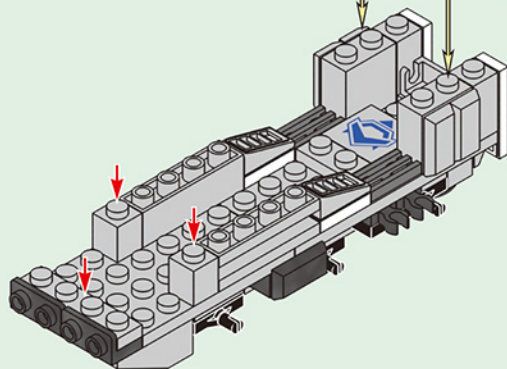
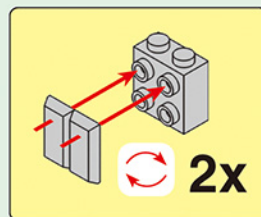



2x



2x

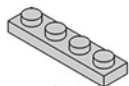

1x

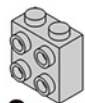

2x

10

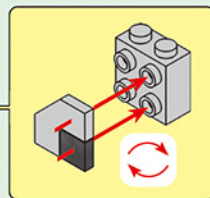
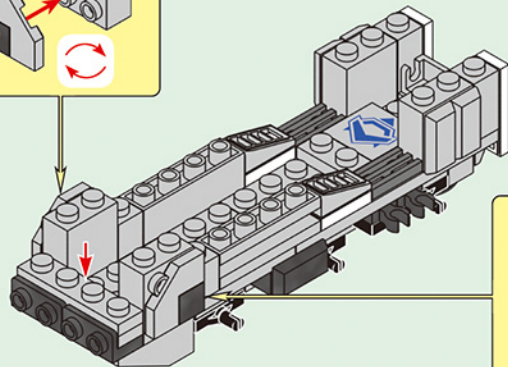
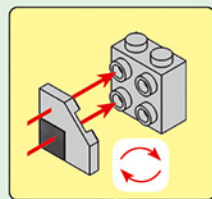



2x



1x



1x



4x



2x

11

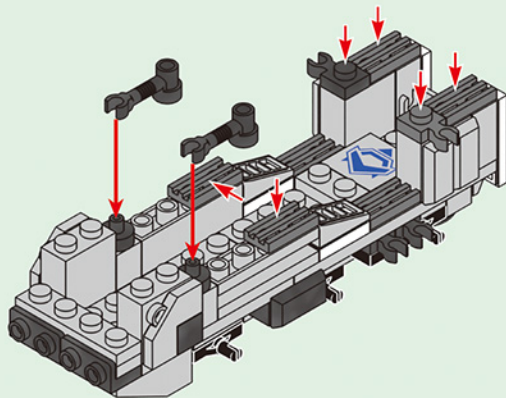



2x



1x



4x

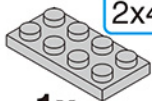

1x

12

1:1



3

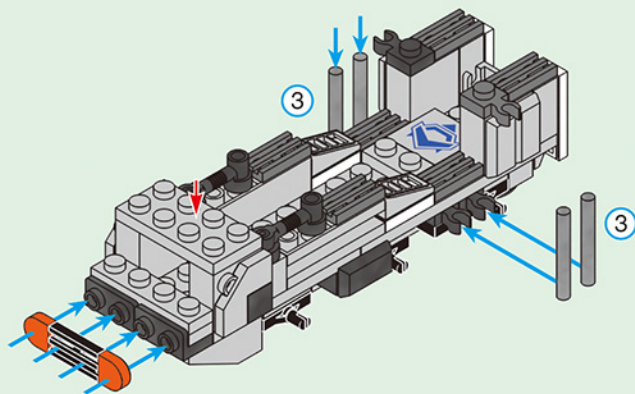

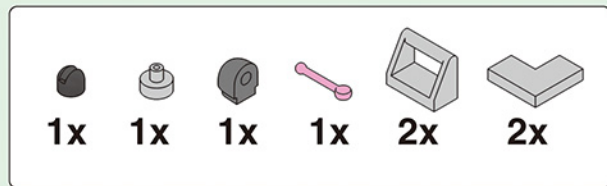

13

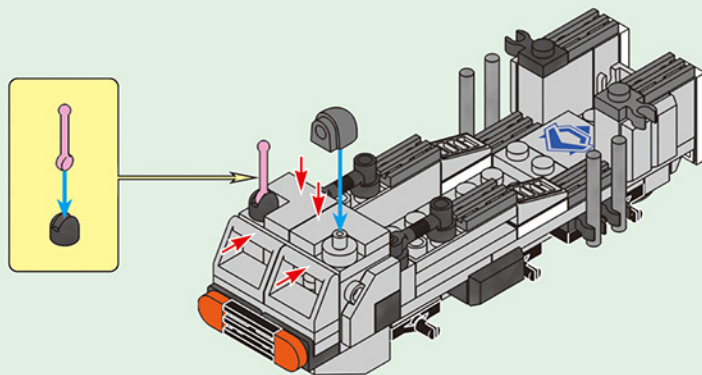



2x



1x



1x



2x



2x



1x

14.1

1

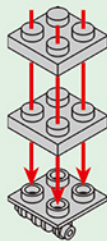

2

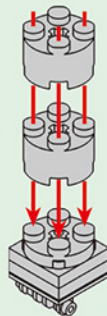

3

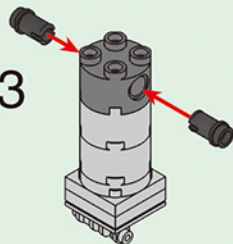

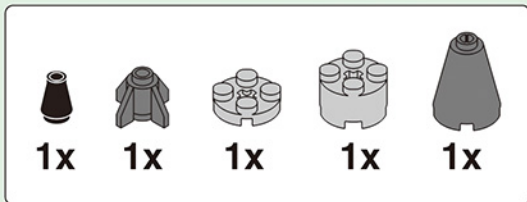

14.2

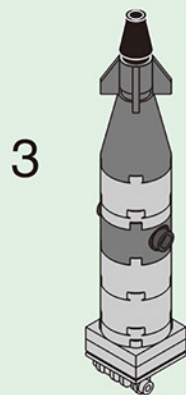
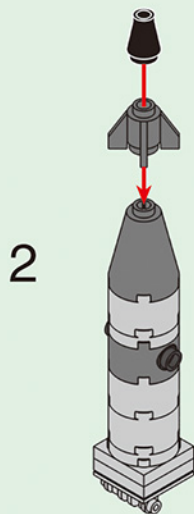
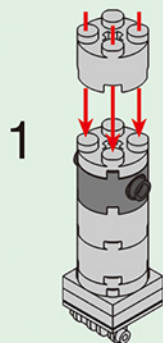

15

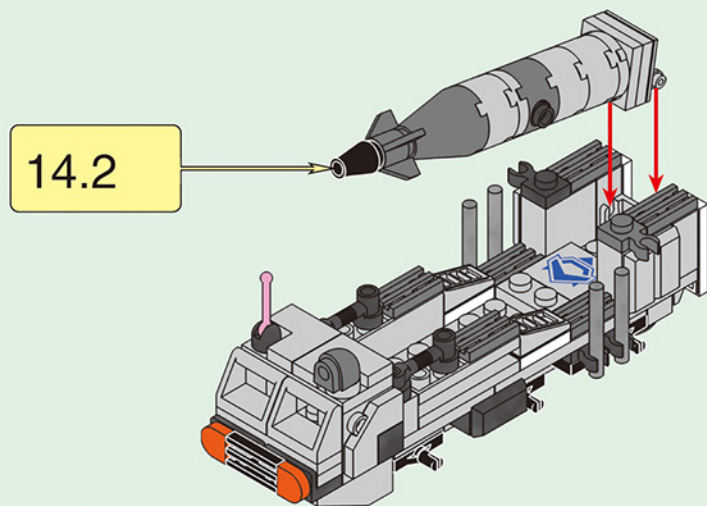



16

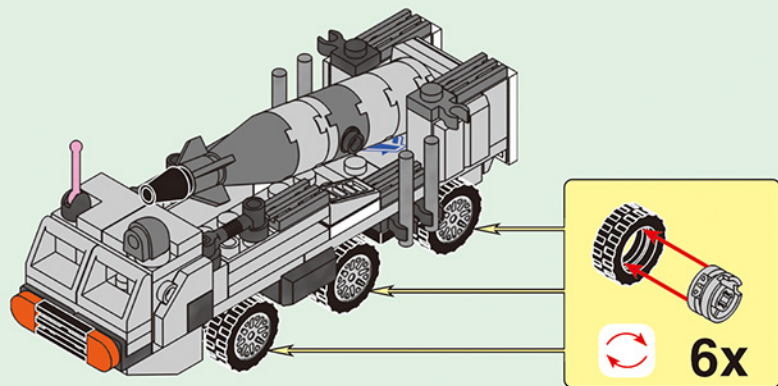

F2

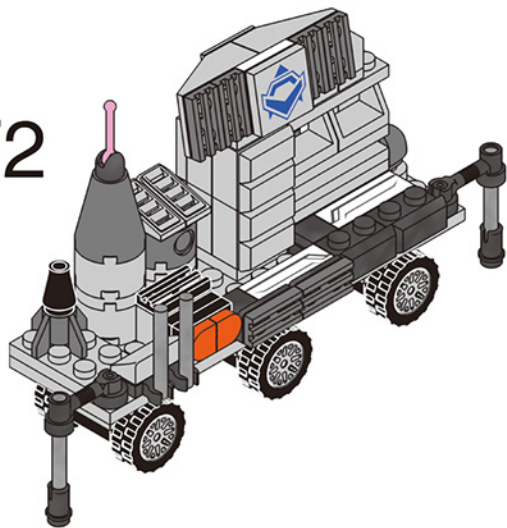

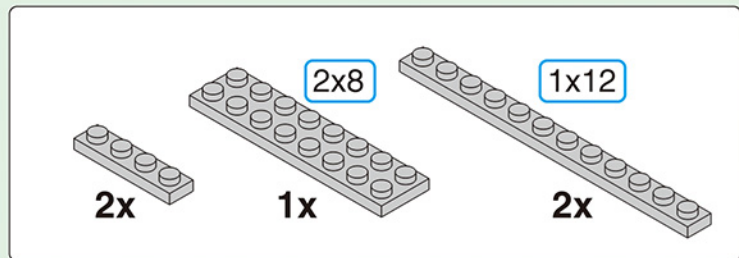

1

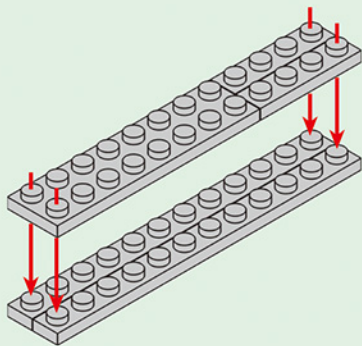



1x

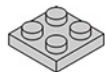

3x



3x

2

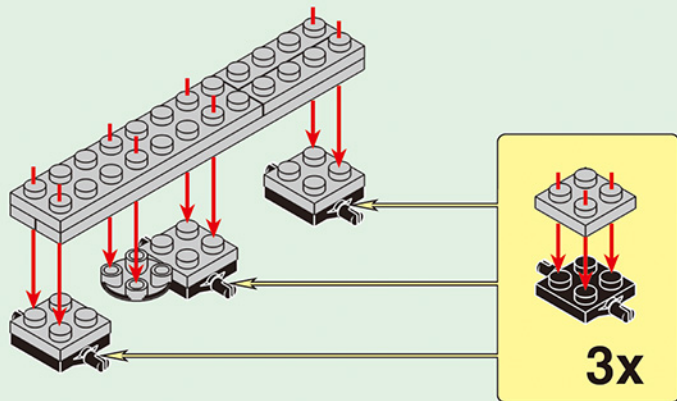

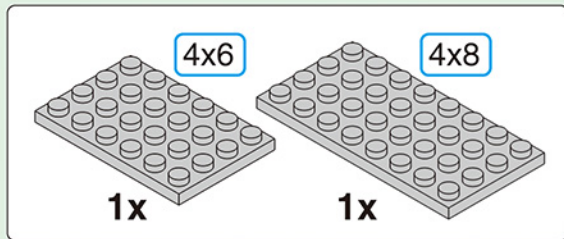

3

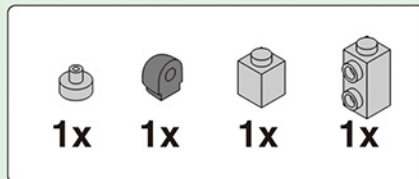
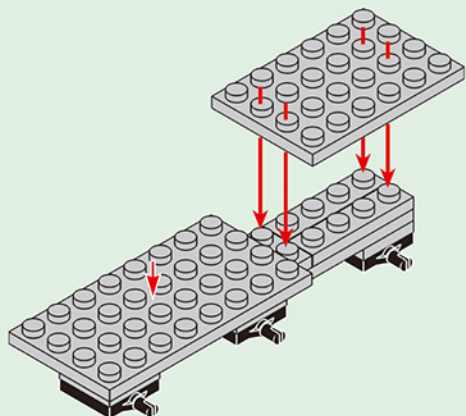

4

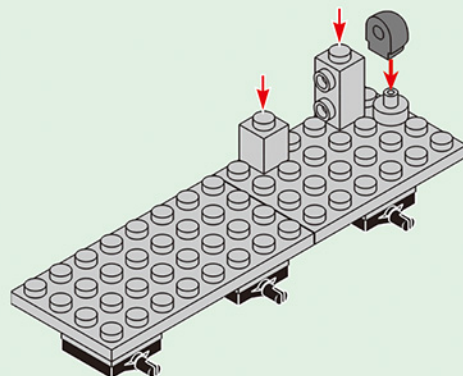

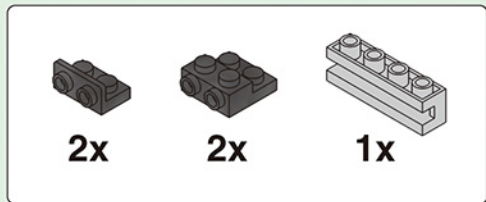

5

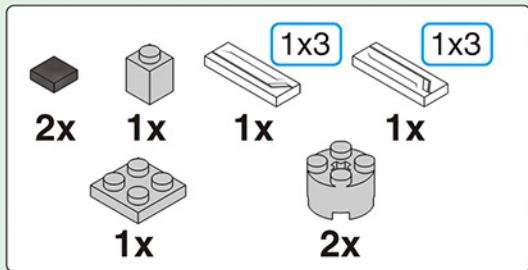
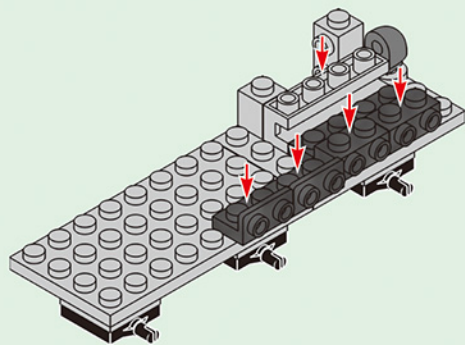

6

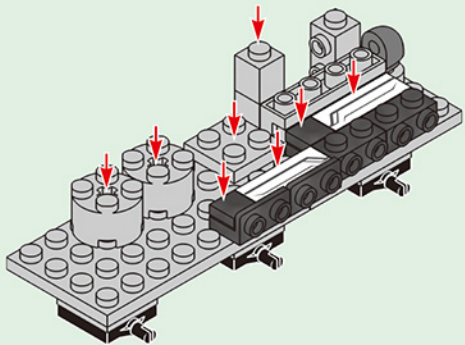



2x



1x



2x



1x

7

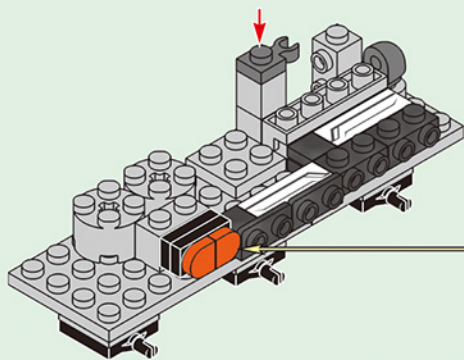

1

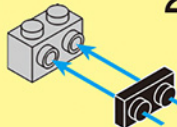

2

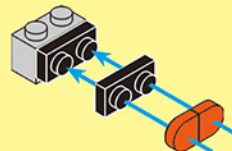

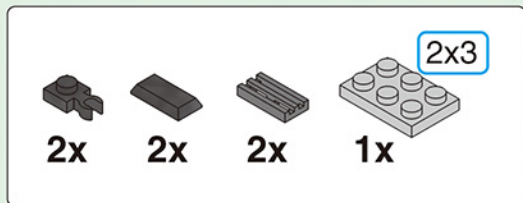

8

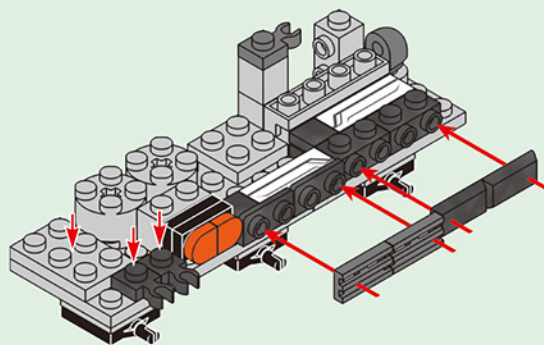



3x



1x



1x

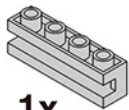

1x

9

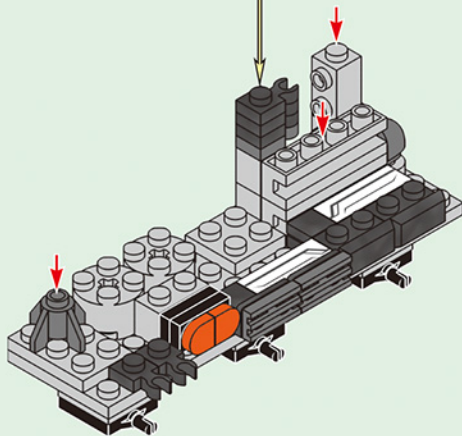
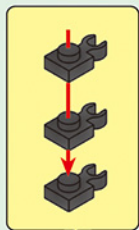

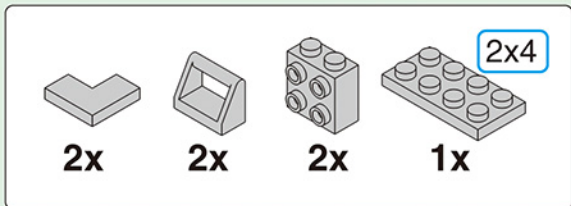

10

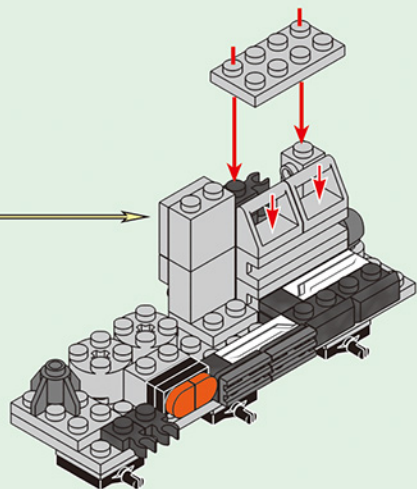
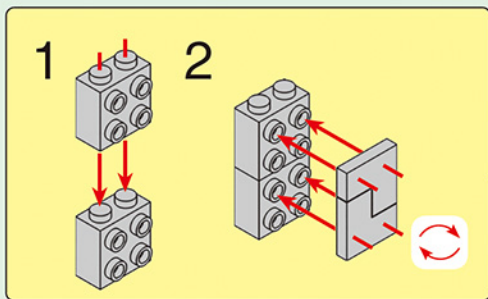

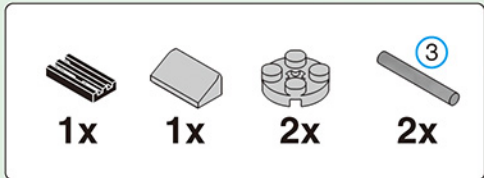

11 1:1 3

The number 11 is displayed in a large font. To its right, a grey 1x3 Technic beam is shown with a small circular icon containing the number 3.

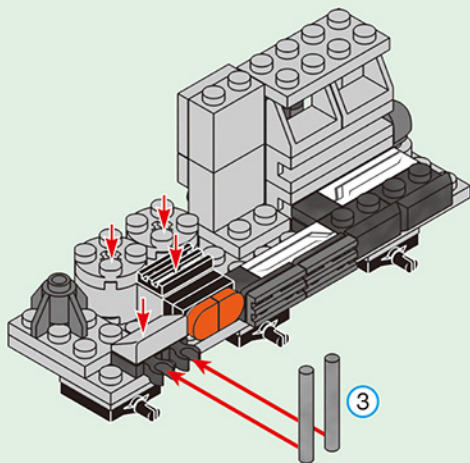



1x



4x



1x

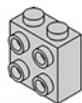

2x

12

1

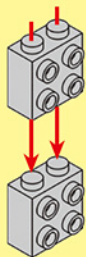

2

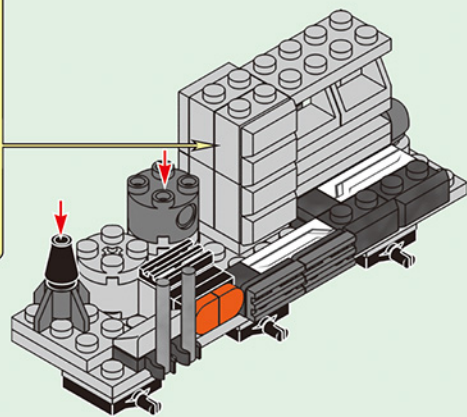
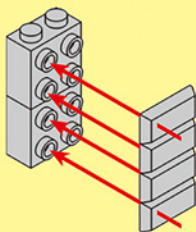

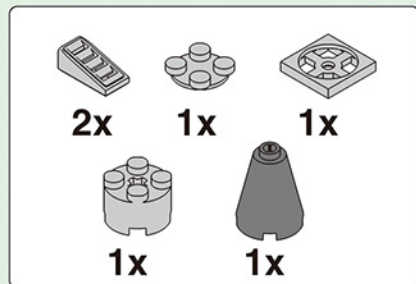

13

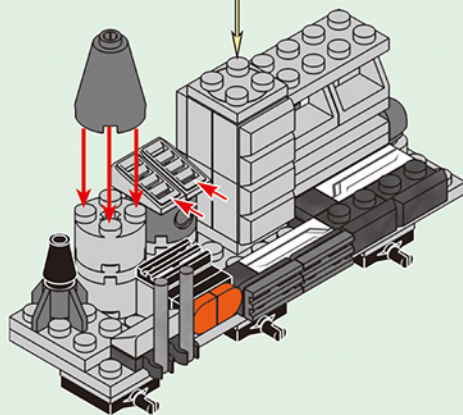
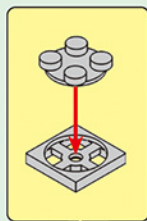



1x



1x



1x



1x



2x

14

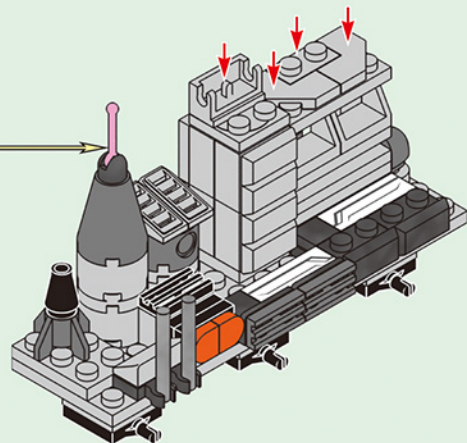
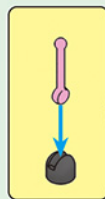



4x



2x



1x



1x

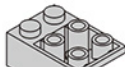

2x

15

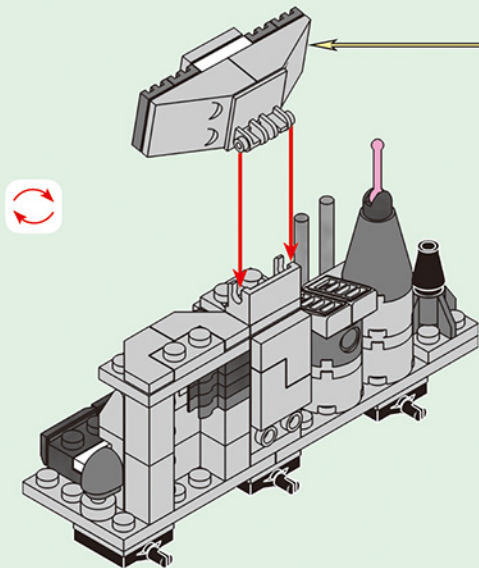

1

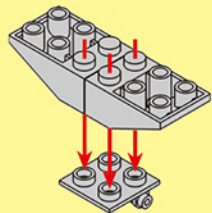

2

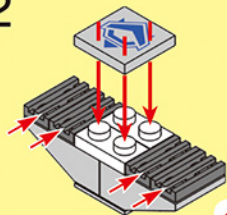



6x



6x

16

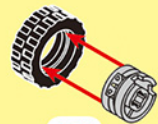
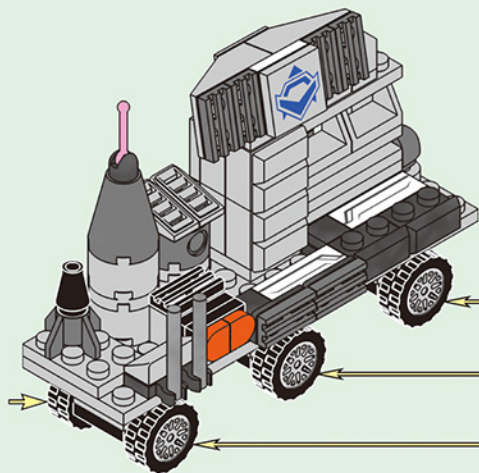

6x

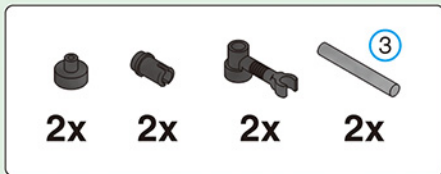

17

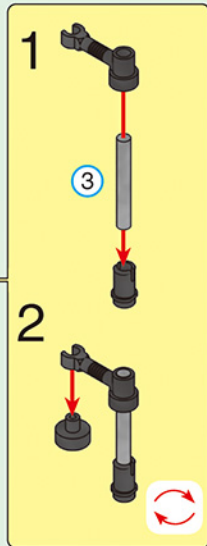
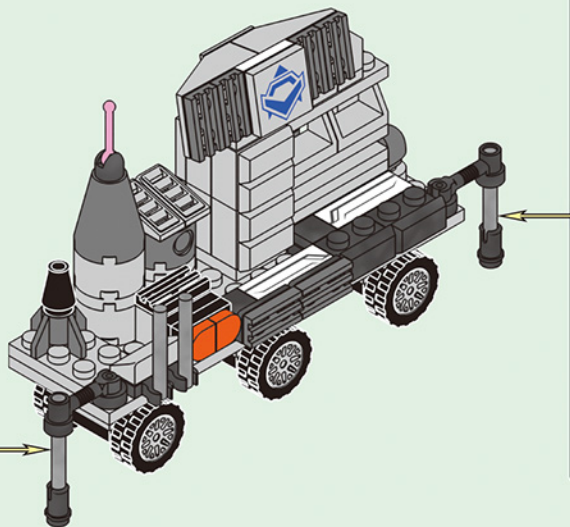
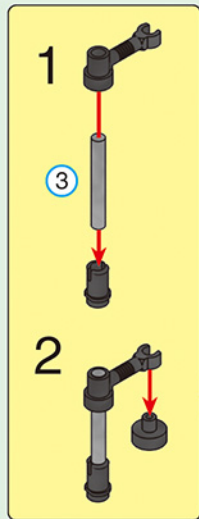

F3

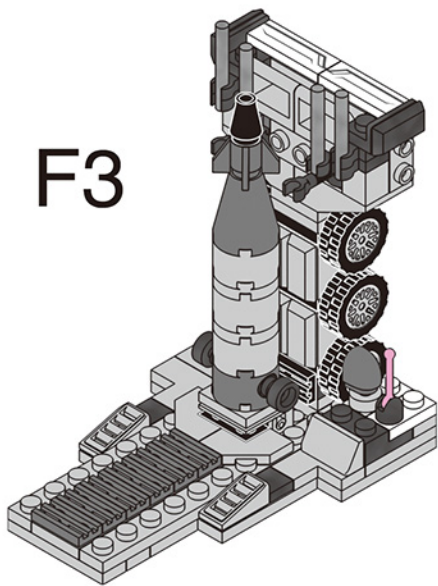

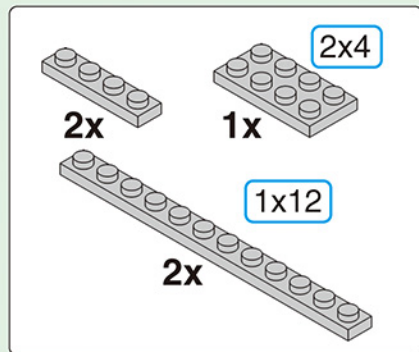

1

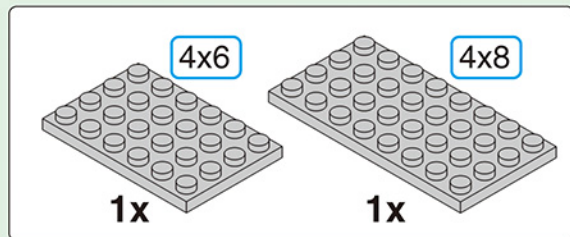
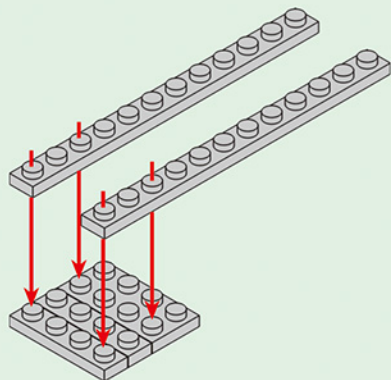

2

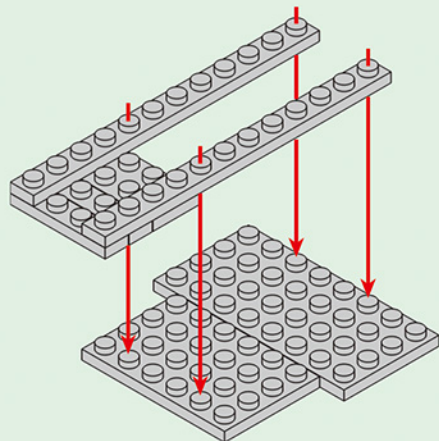

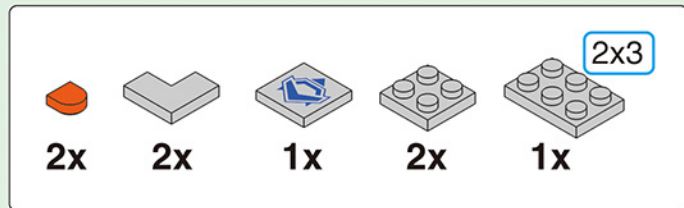

3

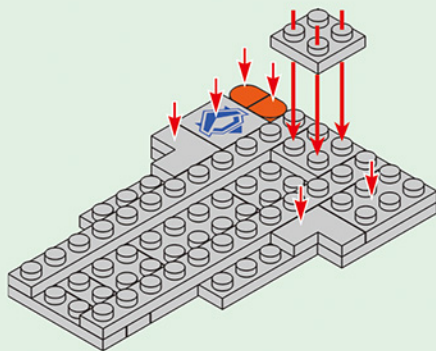

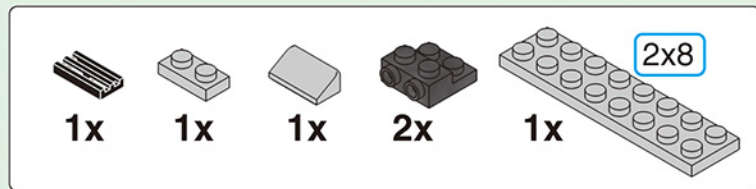

4

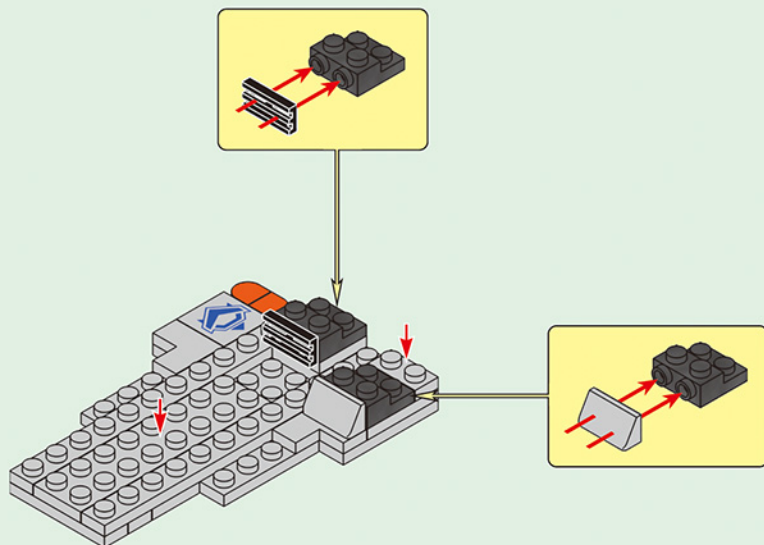



2x



6x



2x



1x



1x

5

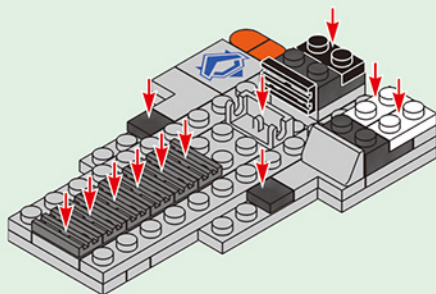



2x



1x



2x

6

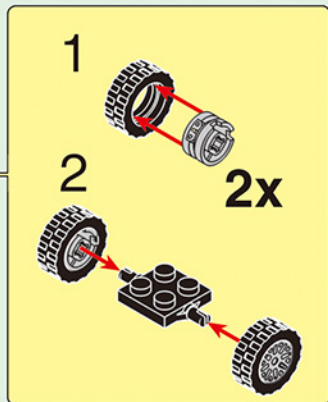
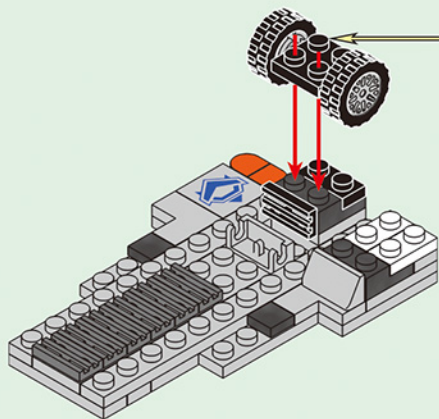



1x



1x



1x



2x



2x

7

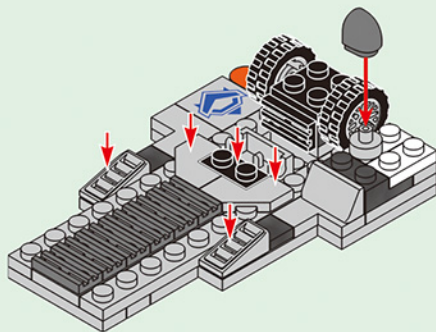

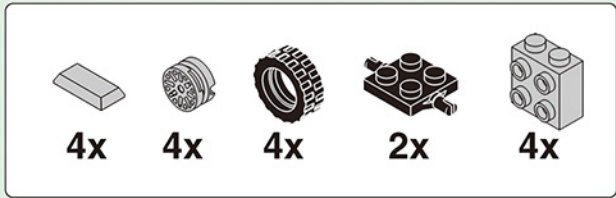

8

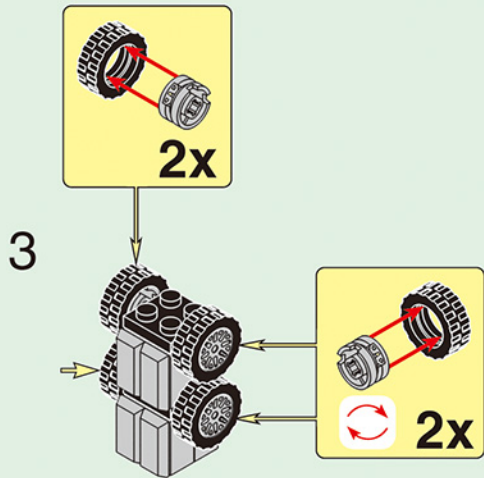
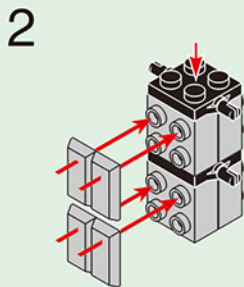
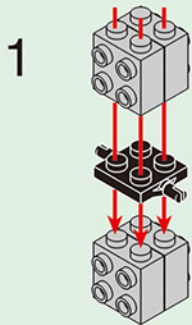

9

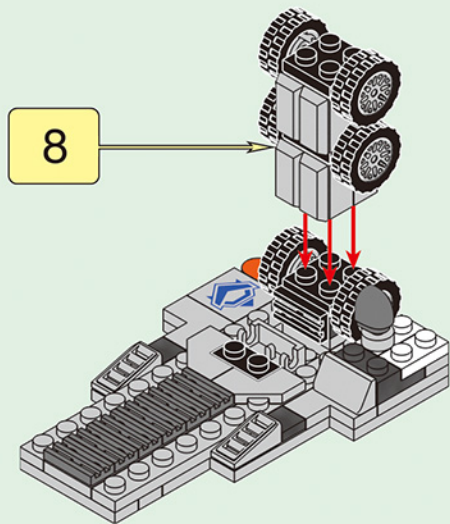



1x



1x



2x

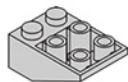

2x

10

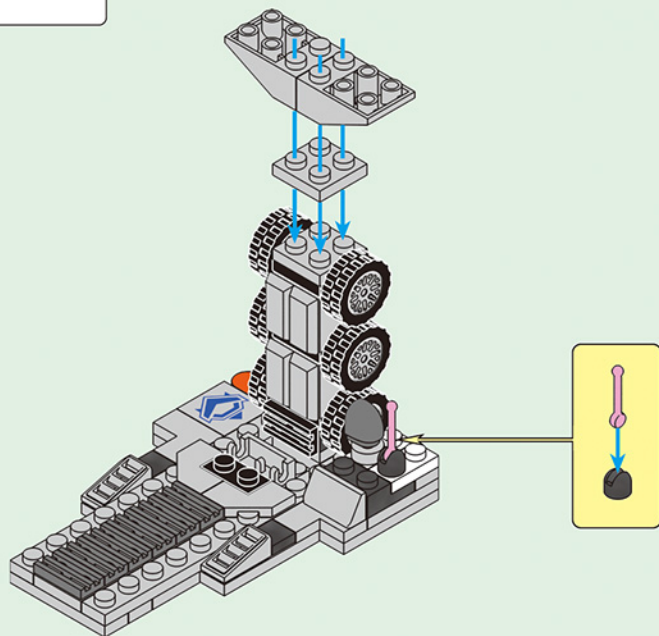



2x



2x



1x

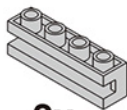

2x

11

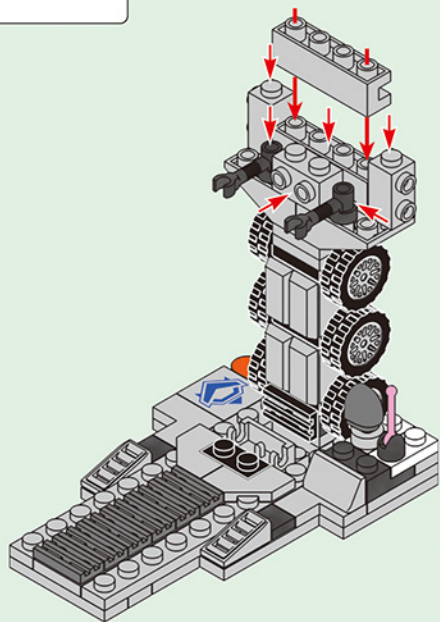



1x



5x



2x

12

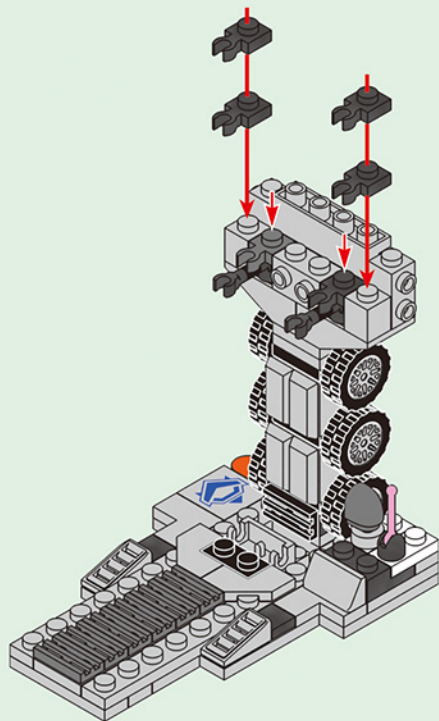



2x



2x



2x

13

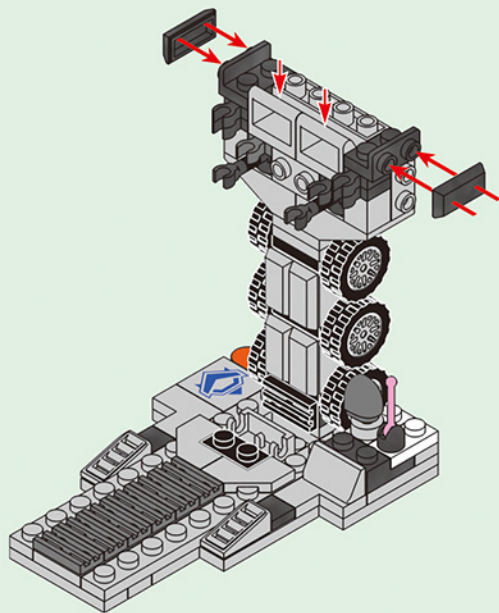

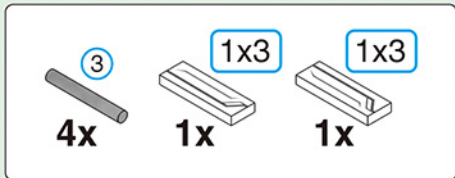

14

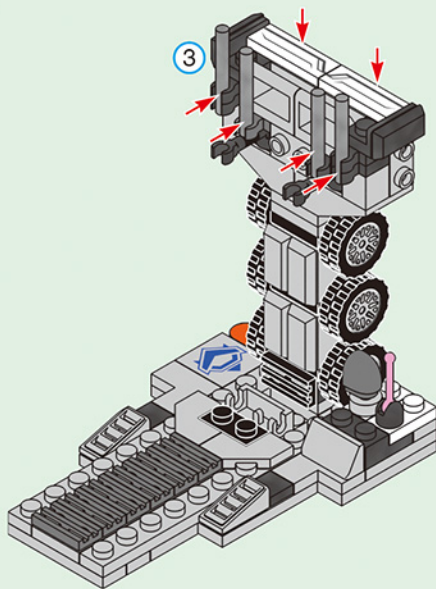

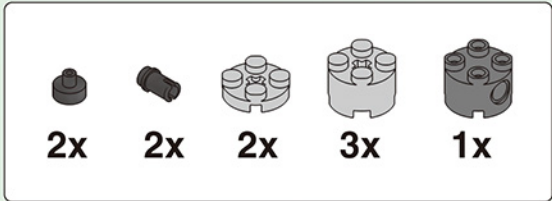

15.1

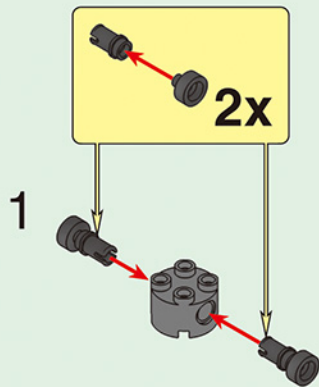

2

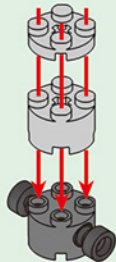

3

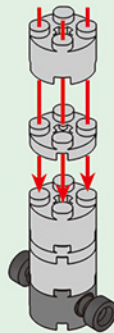



1x



1x



1x



1x



1x



1x

15.2

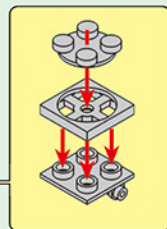
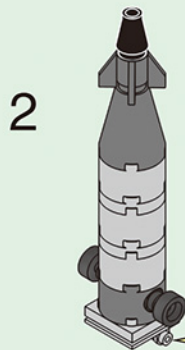
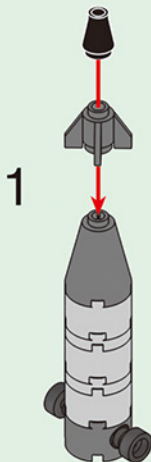

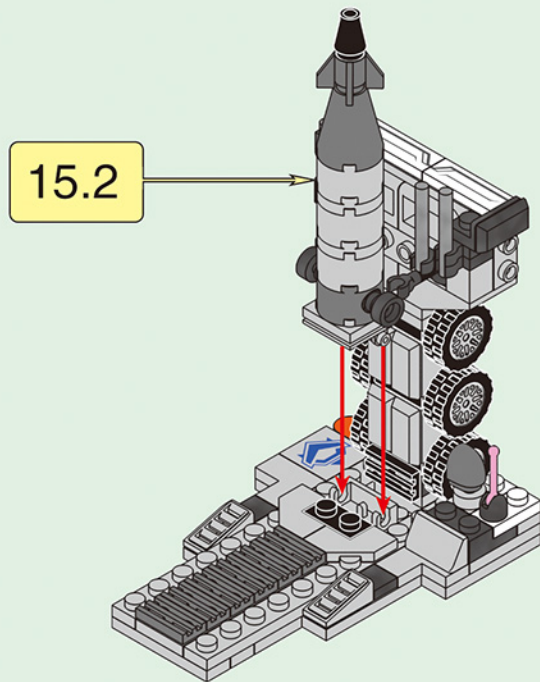

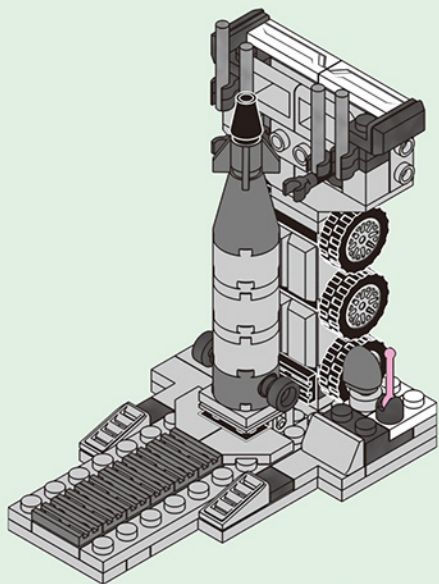

Set up 8 types of
SUPER UNIVERSE BATTLESHIP

