

FREX 450

Flybarless System

INSTRUCTION MANUAL

ALIGN

Lightweight/Agile/Practical
Programmable

FL760

3G

Flybarless System

Page	Contents
1	Safety Notes
2	Features
2	Package Contents
3-5	Flybarless Head Assembly Instruction
6	Parts Identification And Connection Illustration
6	Setup Indicators
7	Control Unit And Sensor Installation
7-16	Usage And Setup Instructions
17-18	3G Flybarless Preflight Check
19-20	3G Flybarless Flight Test Procedure
20	Setup Examples
21	Troubleshooting
22	Q & A
22	Specifications





We appreciate your purchase of Align products.

Please read the manual carefully before assembling and follow all precautions and recommendations located within the manual. Be sure to retain the manual for future reference.

Fly only in safe areas, away from other people. Do not operate R/C aircraft within the vicinity of homes or crowds of people. R/C aircraft are prone to accidents, failures, and crashes due to a variety of reasons including, lack of maintenance, pilot error, and radio interference. Pilots are responsible for their actions and damage or injury occurring during the operation or as a result of R/C aircraft models. Please contact our distributors for free technical consultation and parts at discounted rates when you experience problems during operation or maintenance.

3G Flybarless system is recommended for experienced pilots only.

THE MEANING OF SYMBOLS WARNING LABEL DEFINITIONS

 WARNING	Mishandling due to failure to follow these instructions may result in damage or injury.
 CAUTION	Mishandling due to failure to follow these instructions may result in danger.
 FORBIDDEN	Do not attempt under any circumstances.

NOTICES

WARNING

Before turning on your model and transmitter, check to make sure no one else is operation on the same frequency. Frequency interference can cause your model, or other models to crash. The guidance provided by an experienced pilot will be invaluable for the assembly, tuning, trimming, and actual first flight. (Recommend you to practice with computer-based flight simulator.)

Operate this unit within your ability. To avoid the risk of accidents, do not fly under weary or drowsy conditions.



CAUTION

R/C models are made up various forms of plastic. Plastic is very susceptible to damage or deformation due to extreme heat and cold climate. Make sure not to store the model near any source of heat such as an oven, or heater. It is best to store the model indoors, in a climate-controlled, room temperature environment.

During the operation of the helicopter, the main rotor and tail rotor will be spinning at a high rate of speed. The blades are capable of inflicting serious bodily injury and property damages. Be conscious of your actions, and careful to keep your face, eyes, hands, and loose clothing away from the blades. Always fly the model a safe distance from yourself and others, as well as surrounding objects. Never take your eyes off the model or leave it unattended while it is turned on. Immediately turn off the model and transmitter when you have landed the model.



FORBIDDEN

To ensure operational safety, do not attempt to modify and alter this product. Please use only factory spec replacement parts listed in the manual. This product is intended for recreational R/C model use only. Do not exceed the product's intended limit, nor use it for unlawful purposes.

This product is composed of many precision electrical components. It is critical to keep the model and associated equipment away from moisture and other contaminants. The introduction or exposure to water or moisture in any form can cause the model to malfunction resulting in failure or a crash. Do not operate or expose to rain or moisture.

R/C helicopters fly at high speed, thus posing a certain degree of potential danger. Choose a legal flying field consisting of flat, smooth ground without obstacles. Do not fly near buildings, high voltage cables, or trees to ensure the safety of yourself, others and your model.



- 3Axis** 3-axis gyroscopic flybarless system to simulate the stability of mechanical flybar system, yet at the same time achieving agile 3D performance.
- SMM** Utilizes Silicon Micro Machine (SMM) sensors for excellent stability.
- 12bit** 12 bit processors providing ultra high resolution, resulting in highly precise controls
- USB** Software upgradable through PC interface adapter (sold separately)
- Easy** Simplistic setup process without the need of external devices. Setup is done through 5 steps and 2 sensitivity adjustments. Rudder setup is identical to GP780 gyro, minimizing learning curve.
- Energy** Flybarless system dramatically improves 3D power output and efficiency, resulting in reduced fuel or electricity consumption.
- Stable** Highly sensitive gyroscopic sensors combined with advanced control detection routine providing higher hovering and aerobatic stability than other flybarless system
- CCPM** Suitable for all CCPM and mechanical mixing system.
- T-REX 250-700** Comaptible with helicopter of all sizes from T-Rex 250 to T-Rex 700.
- Pitch Gauge** Innovative pitch gauge as an aid to facilitate pitch adjustments.
- 300Hz** High frame rate signal output for faster and higher precision servo response.
- 3V-8.4V** Capable to operate between 3V to 8.4V, compatible with high voltage servos.
- Small** Small footprint, light weight, minimalists and reliable design.
- RoHS** RoHS compliant.

3 · PACKAGE CONTENTS

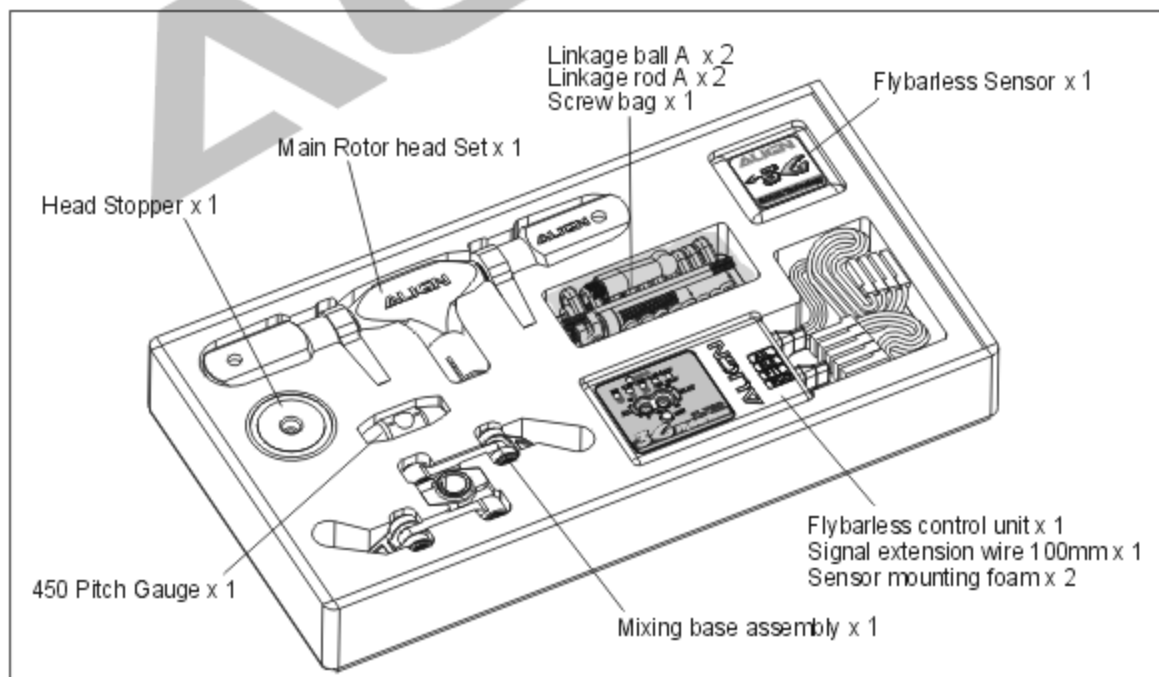

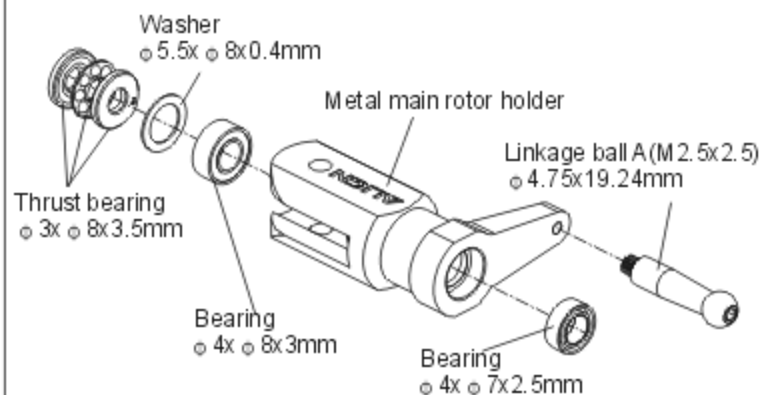

Apply a small amount of T43 thread lock when fixing a metal part.



Apply grease on thrust bearing.

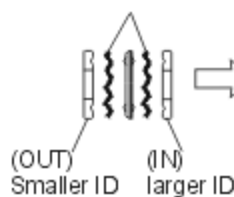

Metal main rotor holder

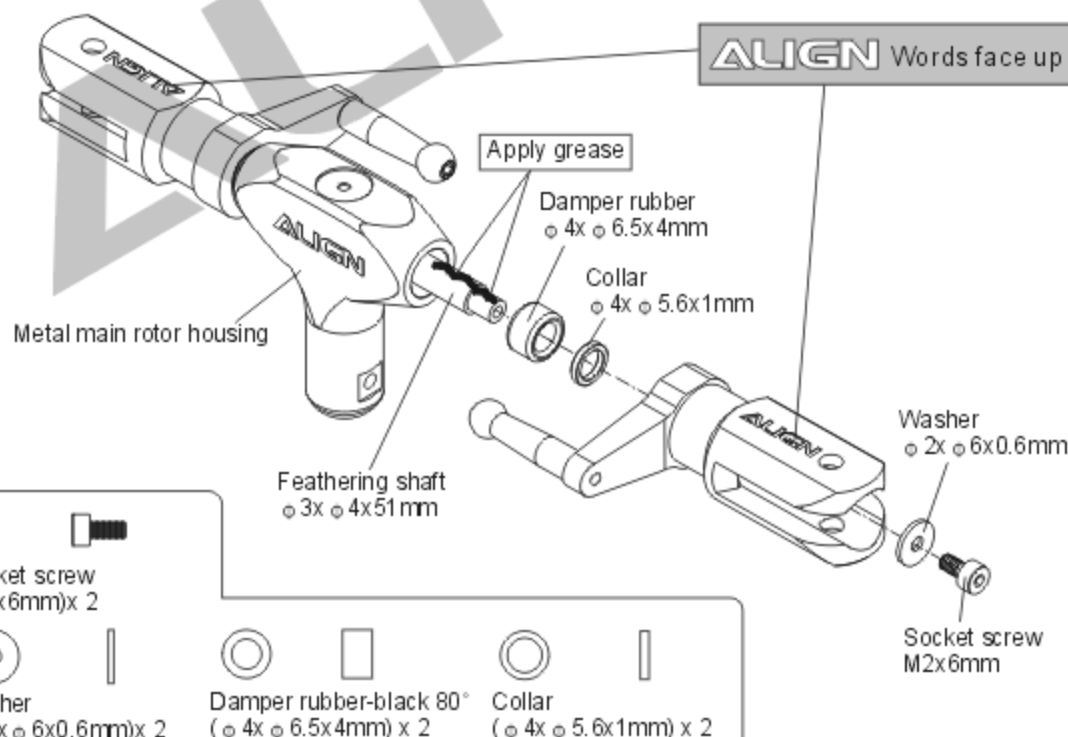
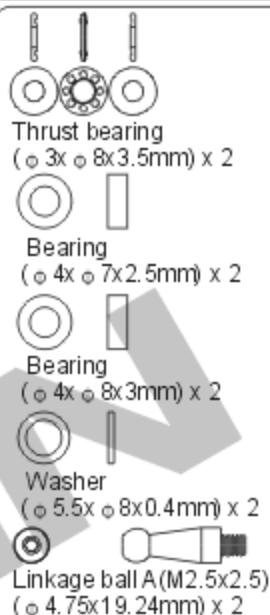

Socket button head screw
(0#x4mm) x 4

Socket screw
(M2x6mm) x 1

Socket screw
(M2x8mm) x 1

Socket screw
(M2x12mm) x 1

Socket collar screw
(M2x12mm) x 1

M2 Nut x 1

Bearing
○ 2x ○ 5x ○ 6x2.3mm x 4

Bearing
(○ 1.5x ○ 4x2mm) x 4

Washer
(○ 2x ○ 3.6x0.2mm) x 2

Apply a small amount of
T43 thread lock when
fixing a metal part.

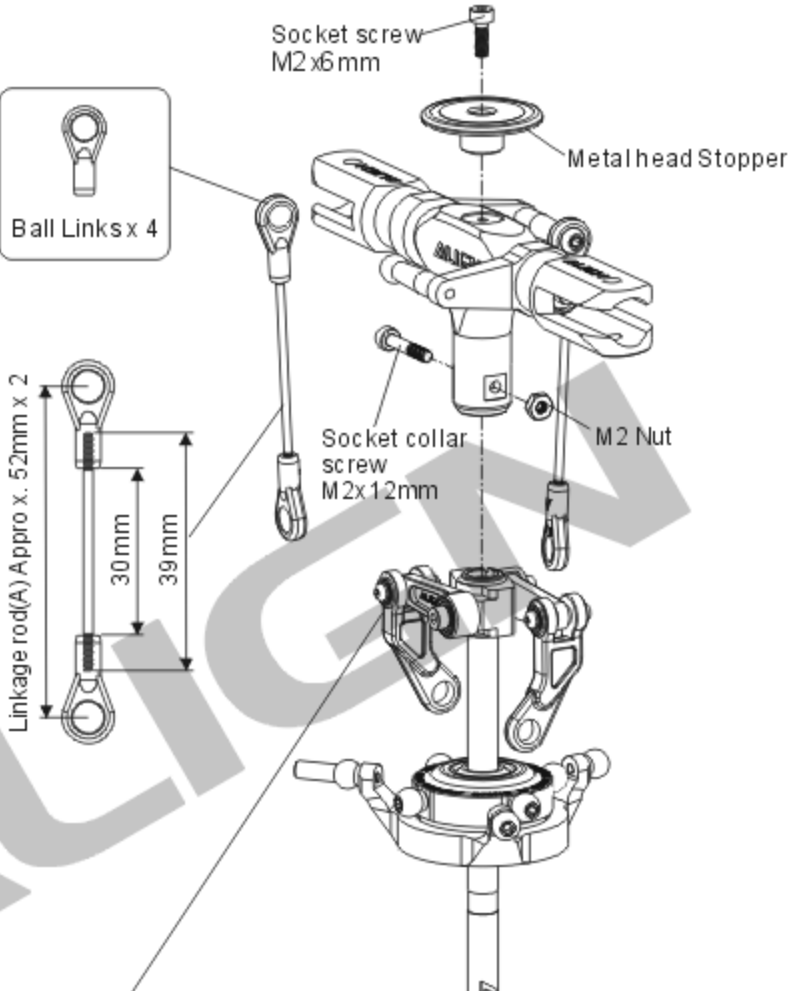

When tightening a screw to the wash out base, please tighten it firmly but not over tightened. over tighten will make the screw strip.

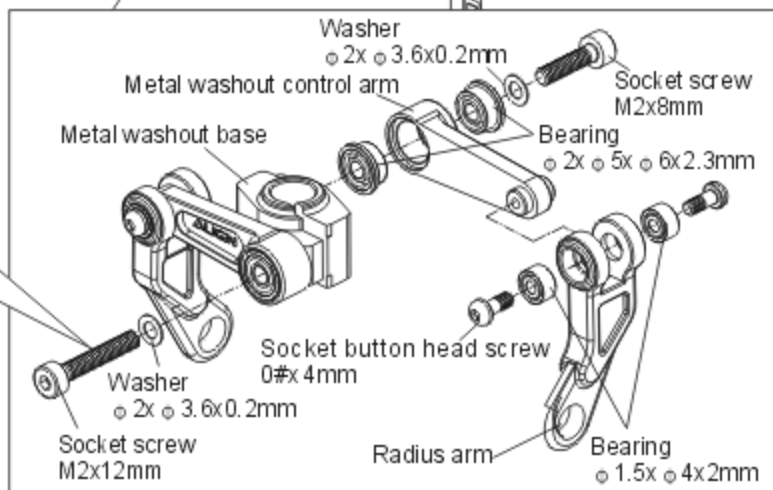

450 SPORT

450 SEV2

450 SE

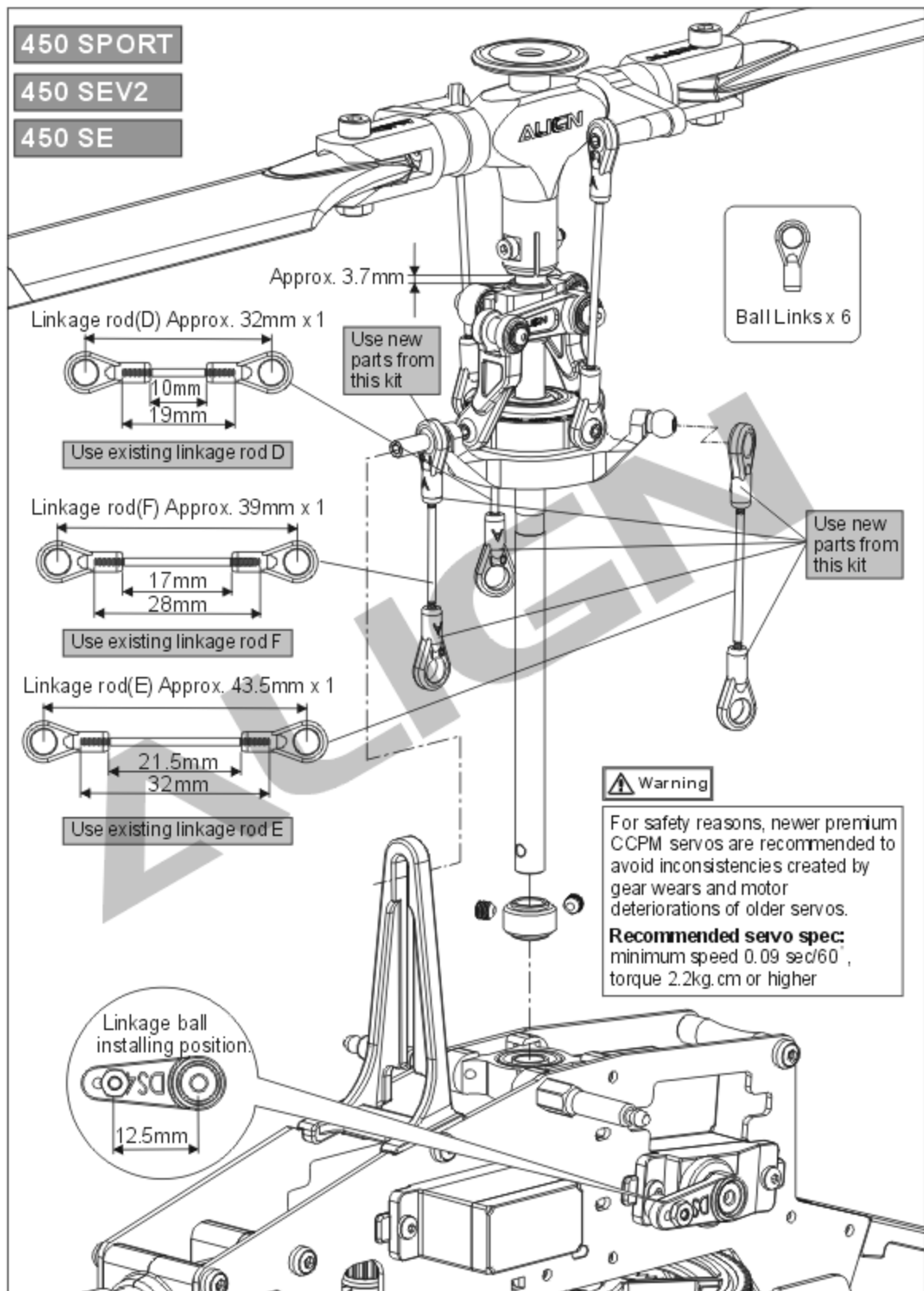

Approx. 3.7mm

Linkage rod(D) Approx. 32mm x 1

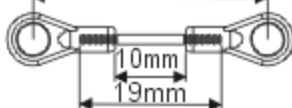

Use existing linkage rod D

Use new parts from this kit

Ball Links x 6

Linkage rod(F) Approx. 39mm x 1

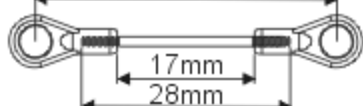

Use existing linkage rod F

Use new parts from this kit

Linkage rod(E) Approx. 43.5mm x 1



Use existing linkage rod E

Warning

For safety reasons, newer premium CCPM servos are recommended to avoid inconsistencies created by gear wears and motor deteriorations of older servos.

Recommended servo spec:
minimum speed 0.09 sec/60° ,
torque 2.2kg.cm or higher

Linkage ball installing position.



PARTS IDENTIFICATION AND CONNECTION ILLUSTRATION

Flybarless Sensor

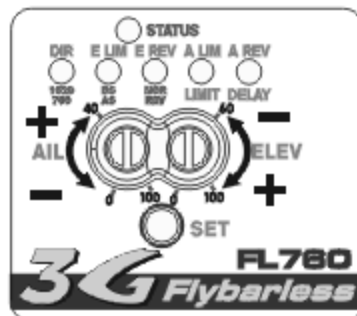

Flybarless Control Unit

Status LED
Setup Indicator

Elevator Gain
SET Button
Aileron Gain

Insert plugs into receiver as per labels

AILERON dual power bus receiver or dual output BEC.
ELEVATOR
PITCH
RUDDER output BEC.
SENSITIVITY

AIL
ELE
PIT

Cyclic and rudder servos are on independent power bus for compatibility with dual power bus receiver or dual output BEC. (Example: Swashplate servo 7.4V and rudder servo 5.2V)

RUD
Step down Voltage Regulator (optional)

The default factory setting for aileron and elevator gain is 50% (dial turned to 12 o'clock position). If left/right or forward/aft oscillation is noticed, reduce the AIL or ELE gain 10 degrees at a time, until the oscillation disappears.

If helicopter drifts left/right or forward/aft during hover, increase the AIL or ELE gain 10 degrees at a time until drifting is eliminated.

6 · 3G FLYBARLESS SETUP INDICATORS

Flybarless system setup mode:

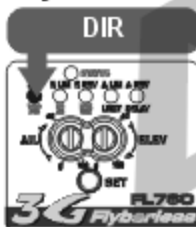

Direct mode bypassing gyro, for mechanical travel and neutral point setup.



Collective mixing type recognition and elevator endpoint settings

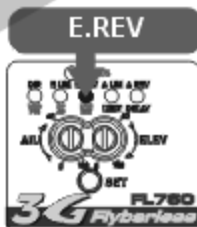

Elevator reverse settings



Aileron endpoints settings

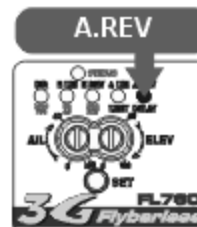

Aileron reverse settings

Rudder gyro setup mode:



Servo frame rate settings (1520 μ s and 760 μ s)



Digital/Analog servo settings



Rudder Servo Reverse settings

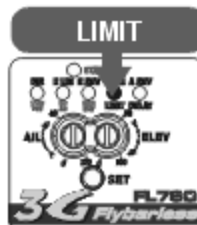

Rudder endpoints settings

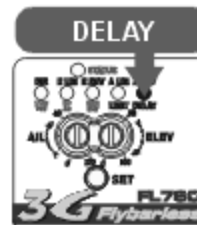

Rudder servo delay, and helicopter size settings

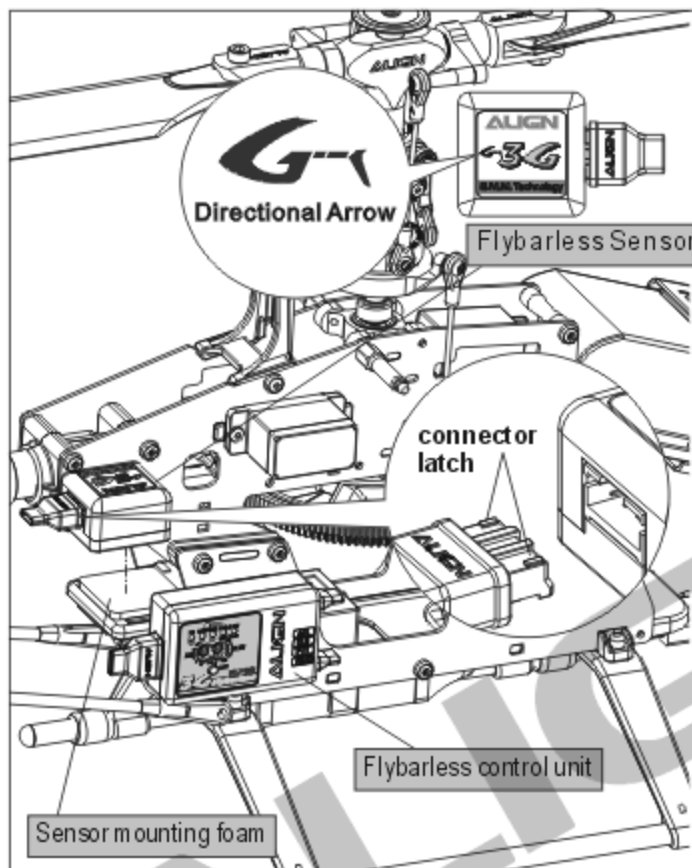

CAUTION

Sensor must be installed with arrow pointing to **front** or **rear** of the helicopter as shown in diagram, **level**, and away from vibration sources. If excess vibration from helicopter frame is affecting flybarless sensors causing instability, two sensor foams can be used to mount the sensor. If problem persists, attempts should be made to eliminate vibration source, or reduce headspeed.

CAUTION

when connecting the wire harness between control box and sensor, push the connector all the way in, and make sure the connector latch engages the unit with a "click" sound. The connection needs to have sufficient slack to avoid vibrations induced disconnects. Disconnects during flight will result in loss of control and crash of the model.

8 · USAGE AND SETUP INSTRUCTIONS

SETUP PRE-CHECK

1. Connect the receiver and servos to the flybarless control unit as per diagram found on page 6.
2. Digital servos must be used on cyclic to avoid damage to servos.
Recommended servo spec: minimum speed 0.09 sec/60, torque 2.2kg.cm or higher.
3. Transmitter trim tabs must be centered before entering the setup process. It can be moved after setup is complete to trim the heli.
4. 3G Flybarless contains two independent power circuits to enable the use of different voltage sources through the receiver (For example, 7.4V to the cyclic servos, 5V to the gyro and rudder servo).
If there is only one 7.4V power source, a step down voltage regulator is required (available separately) to prevent rudder servo from burning out.



To prevent voltage instability, do not use step down voltage regulator if power source is already at 5V.

Please consult your servo manuals and ensure proper voltage are supplied to the servos.

5. When the 3G flybarless system is installed for the first time, a few simple setup steps and fly tests need to be performed in the flybarless setup mode. These steps need to be performed only during initial setup, and does not need to be repeated for subsequent flights. Just power up the system normally, check the proper servo operations, and fly. The initial setup procedure only need to be repeated after software upgrade, pitch range reset, or subtrims are added in the transmitter.

FLYBARLESS SYSTEM INITIAL SETUP STEPS

1 .DIR: Direct mode to bypass gyro for mechanical travel and neutral point setup

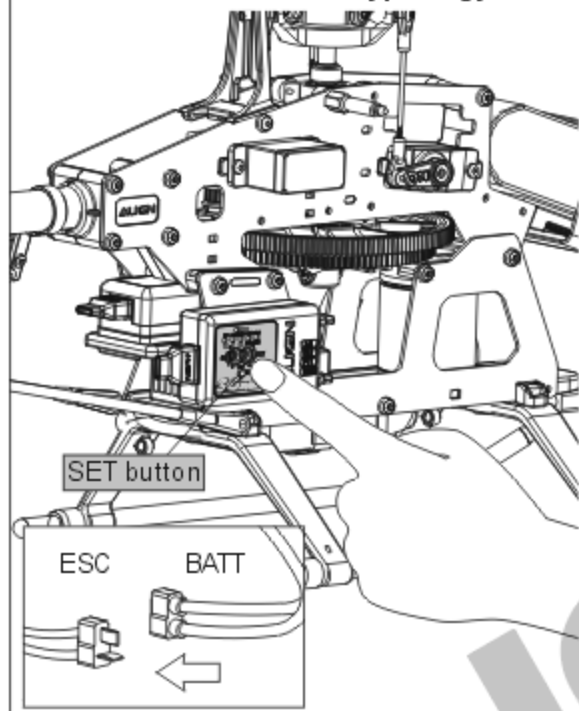

Step 1.1 : Enter the DIR settings

Please unplug the motor power cord before connecting the battery to avoid motor operating while you are doing the setting. Connect the motor power cord after the setting is finished.

Press and hold the SET button while powering up the receiver. Release the button when LED 1-5 begin to cycle. The DIR green LED will light up indicating the gyro has been bypassed for neutral and mechanical travel range setup.

CAUTION

If "STATUS" led flashes in red indicating error entering DIR settings, check connections to the sensor and restart the process.

DIR settings



Transmitter function to servo mapping

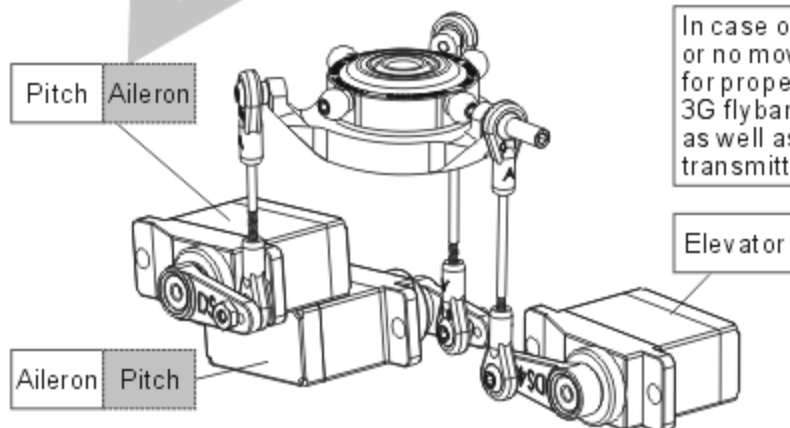

Step 1.2 : Swashplate function check

Verify the correct swashplate movements for PIT, AIL, and ELE inputs.

CAUTION

In case of incorrect servo movement or no movement at all, please check for proper connection between 3G flybarless connection to servos, as well as proper setup on transmitter.

DIR settings



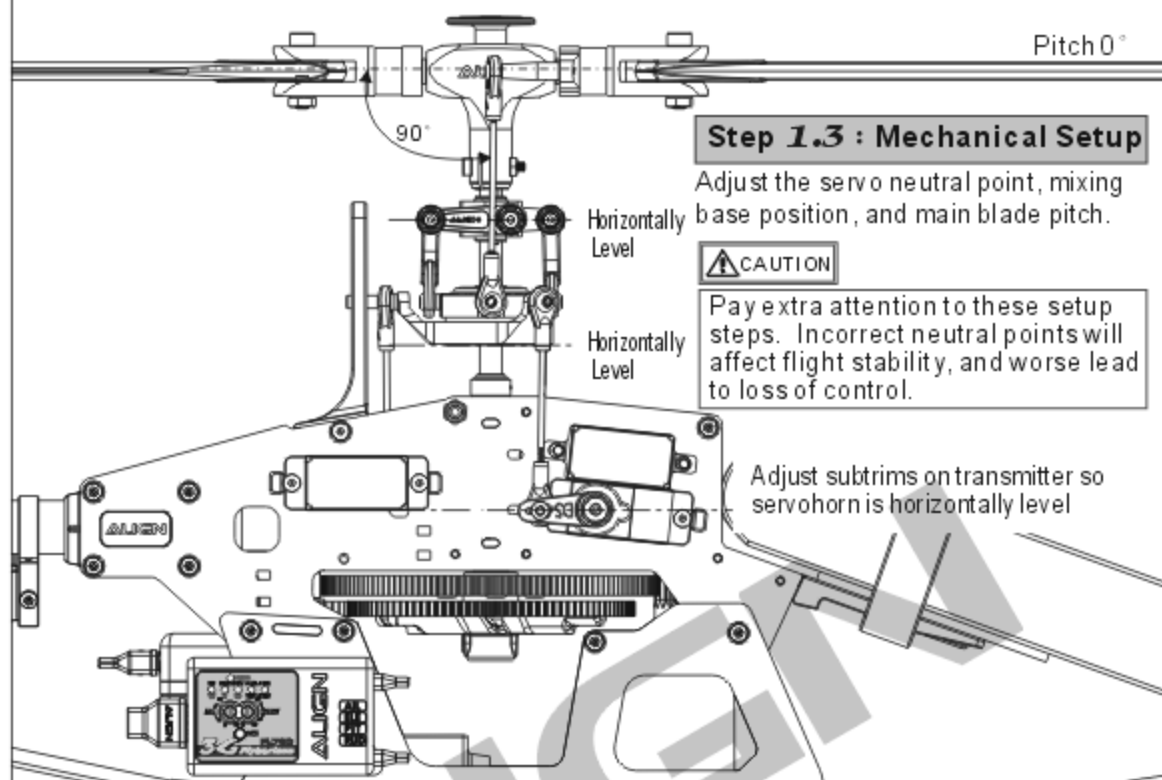

Step 1.3 : Mechanical Setup

Adjust the servo neutral point, mixing base position, and main blade pitch.

CAUTION

Pay extra attention to these setup steps. Incorrect neutral points will affect flight stability, and worse lead to loss of control.

Adjust subtrims on transmitter so servohorn is horizontally level

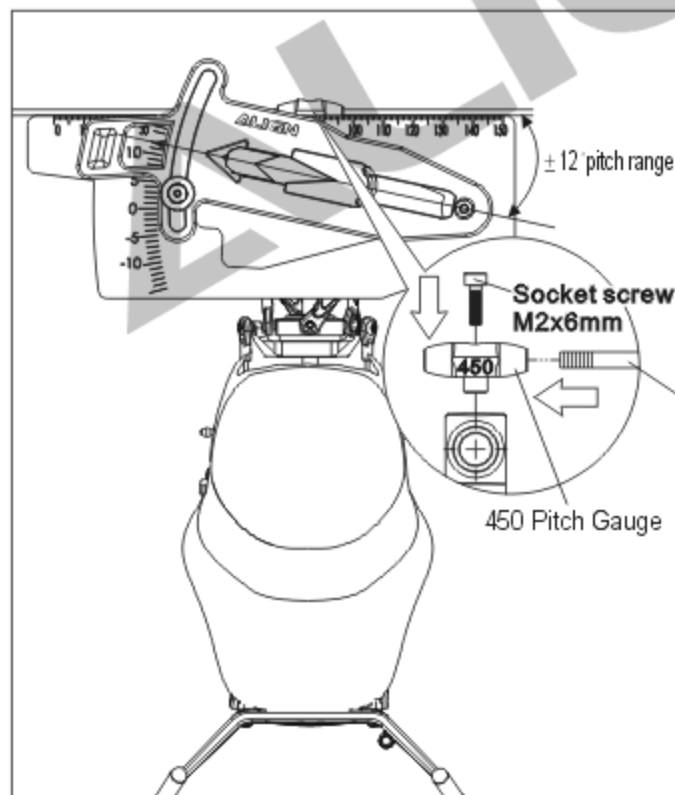

Step 1.4 : Collective pitch setup

Adjust the maximum collective pitch using the transmitter's washplate mixing function (pitch swash AFR). Recommended pitch range $\pm 12^\circ$, maximum pitch range for advanced pilot shall not exceed $\pm 14^\circ$.

CAUTION

Do not adjust individual servos endpoints through the servo AT V/AFR function, use only washplate mixing adjustments. Should any changes made to the endpoints or subtrims on the transmitter in the future, the flybarless system initial setup must be performed again.

Use the original $\phi 2$ flybar

Use the included pitch gauge and the original flybar to aid the adjustment of pitch.

CAUTION

If there are bite marks from the set screw on your flybar, sand it smooth with sandpaper or file for ease of insertion into the temporary flybar mount.

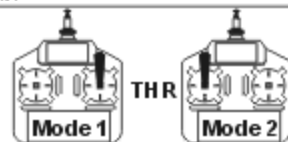

Step 2.2 : Swashplate mixing type recognition and elevator endpoint setup

With all channels stationary, move the transmitter elevator stick **forward**, and then back to center position. This completes the swashplate mixing type recognition process.
The control unit will determine the CCPM mixing ratio or traditional mechanical mixing maximum elevator endpoints.

CAUTION

Throttle stick position where main pitch is 0 degree must be maintained through this setup process.

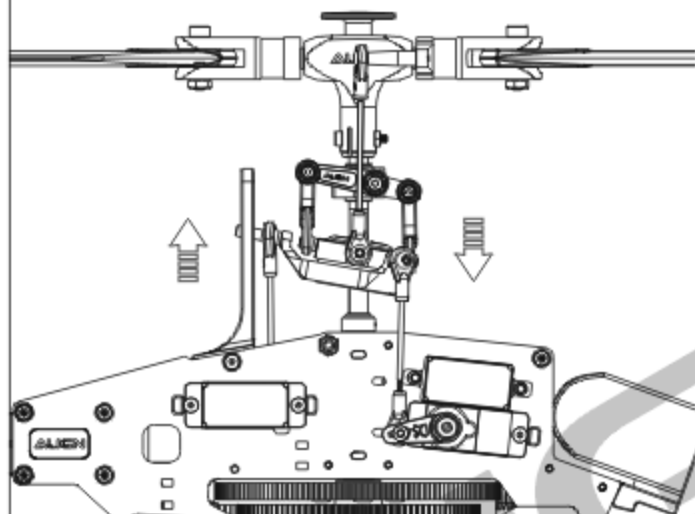

Throttle stick must be maintained

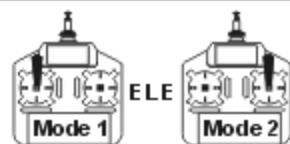

E.LIM settings



3. E.REV elevator reverse setup mode :

Press the SET button to enter E.REV setup mode.
The E.REV LED will lit up after E.LIM turns off.

This setup mode sets the elevator gyro direction

1. Tilt the helicopter forward as shown in diagram, and check if swashplate is tilting correctly toward the back.
2. If the swashplate is tilting at the wrong direction, move the transmitter elevator stick until STATUS LED changes color, and re-check the swashplate tilting direction.

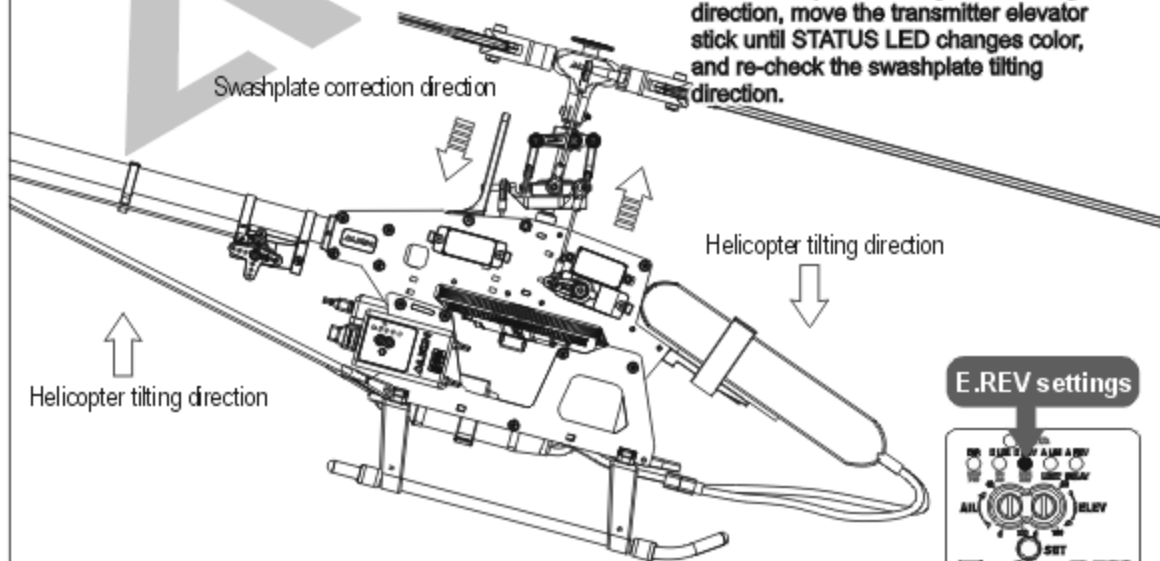

E.REV settings



4. A.LIM aileron endpoints setup :

Press the SET button to enter A.LIM setup mode. The A.LIM LED will lit up after E.REV turns off. With all channels stationary, move the transmitter aileron stick to the right, and then back to center position. This completes the aileron endpoint setup process. The control unit will determine the maximum aileron endpoints

CAUTION

The throttle stick position where main pitch is 0 degree must be maintained through this setup process.

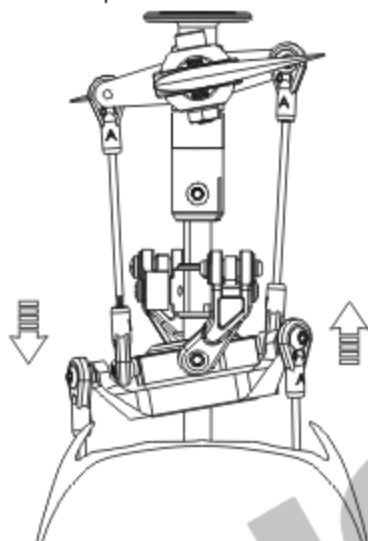

Throttle stick must be maintained

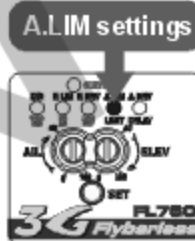

5. A.REV aileron reverse setup mode :

Press the SET button to enter A.REV setup mode. The A.REV LED will lit up after A.LIM turns off.

Tilt the helicopter right as shown in diagram, and check if swashplate is tilting correctly toward the left. If the swashplate is tilting at the wrong direction, move the transmitter elevator stick until STATUS LED changes color, and re-check the swashplate tilting direction.

Press the SET button again, and the control unit will restart, with all LED's flashing.

CAUTION

3G Flybarless system must remain stationary during startup. Do not move the helicopter until the swashplate jumps up and down slightly 3 times, indicating the completion of initialization. (please refer to page 17 step 3)

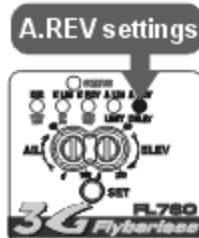
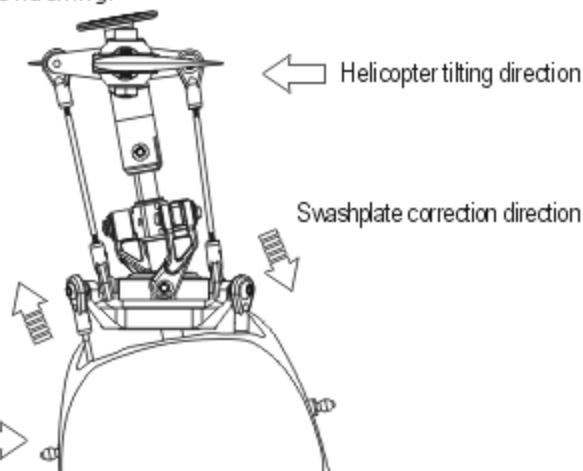

RUDDER GYRO SETUP

After the system reboots, flybarless setup is completed. Now the rudder gyro needs to setup with similar procedure as Align's GP780 gyro. Push and hold the SET button for 2 seconds to enter the rudder gyro setup mode.

If your transmitter has the following settings, please disable it or set the value to zero.

- ATS
- Pilot authority mixing
- Throttle to rudder mixing
- Rudder to gyro mixing
- Pitch to rudder mixing
- Revolution mixing

CAUTION

3G Flybarless rudder gyro has the factory setting of 1520 μ s and DS digital servo. Double check your servo spec and change the gyro setting as needed to avoid damages to the servo.

Step 1 : 1520 μ s (standard) or 760 μ s (narrow band) servo frame rate setup.

3G Flybarless system is compatible with both the 760 μ s narrow frame rate servos (such as Futaba S9256, S9251, BLS251), as well as the standard 1520 μ s frame rate servos (most others). Proper frame rate must be selected based on your servo's specifications.

To enter the setup mode : Press and hold the SET button for 2 seconds until STATUS LED flashes. The 1520/760 LED will light up indicating servo frame rate setup mode. Push the transmitter rudder stick left or right to select the frame rate. For example, if rudder is pushed to the left (or right) and STATUS LED turns green, the frame rate is set to 1520 μ s. To set it to 760 μ s, the rudder stick need to be pushed from the center to the opposing end 3 times for the STATUS LED to turn red, indicating frame rate set to 760 μ s.

3G Flybarless panel : Each setting value is labeled on the 3G flybarless control unit with either green or red lettering, which corresponds to the STATUS LED color. Subsequent setup mode is entered by a single press of the SET button. Setup mode will exit if no activity is detected in 10 seconds.

Green LED : 1520 μ s standard band
Red LED : 760 μ s narrow band



Standard/Narrow band mode

Select by moving the rudder stick left and right



Step 2 : DS (digital) / AS (analog) servo selection

There is a direct correlation between servos' speed to gyro's performance. Faster servos are able to execute commands from the gyro at faster and higher precision. Due to the high performance gyro sensors used in the 3G flybarless system, premium high speed digital rudder servos are mandatory for optimal tail performance. Some of the recommended rudder servos include Align DS650, DS620, DS520, DS420, Futaba S9257, S9256, S9254, S9253, or other servos with similar specifications.

Setup method : Press and hold the SET button for 2 seconds to enter the setup mode, then press the SET button to select DS/AS setup mode, as indicated by the lighting of DS/AS LED. Using the transmitter's rudder stick, select either digital servo DS mode (STATUS LED is green), or analog servo AS mode (STATUS LED is red).

CAUTION

Using an analog servo in DS mode will cause damages to the servo.

Green LED : DS digital servo
Red LED : AS analog servo



digital / analog mode

Select by moving the rudder stick left and right



Step 3 : Rudder servo direction check and link adjustment

Move the transmitter rudder stick left/right, and check for the correct direction of the rudder servo. If needed, servo reverse is done from the transmitter's REV (reverse) function.

For tail pitch adjustment, center the rudder servo by either setting the 3G flybarless to normal rate mode (non-heading lock), or press and hold the SET button for 2 seconds. With the rudder servo centered and servo horn at 90 degrees, adjust the linkage length until tail pitch slider is centered on the tail output shaft as shown in diagram.

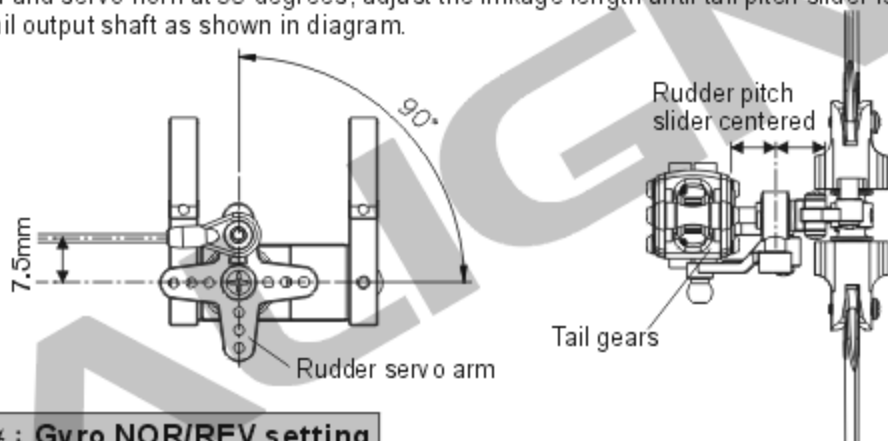

Step 4 : Gyro NOR/REV setting

Lift up the helicopter by hand, and turn it to the left (yaw). Check if the rudder servo is applying correct compensation to the right. If reversed, set the NOR/REV setting as follow.

Setup method : Press and hold the SET button for 2 seconds to enter the setup mode, then press the SET button to select NOR/REV setup mode, as indicated by the lighting of NOR/REV LED. Using the transmitter's rudder stick, select either NOR (STATUS LED is green), or REV (STATUS LED is red).

Green LED : normal direction
Red LED : reverse direction



gyroscope direction settings

Select by moving the rudder stick left and right



Step 5 : LIMIT rudder servo endpoint setting

Press and hold the SET button for 2 seconds to enter the setup mode, then press the SET button repeatedly to select LIMIT setup mode, as indicated by the lighting of LIMIT LED. Push the transmitter rudder stick left until tail pitch slider reaches the end, then center the rudder stick and wait 2 seconds for the STATUS LED to flash red. Then push the rudder stick right until tail pitch slider reaches the end, then center the rudder stick and wait 2 seconds for the STATUS LED to flash red. This completes the left and right endpoint limit adjustment of servo travel. Insufficient servo travel will degrade helicopter performance, while excessive travel will cause binding and damage rudder servo.

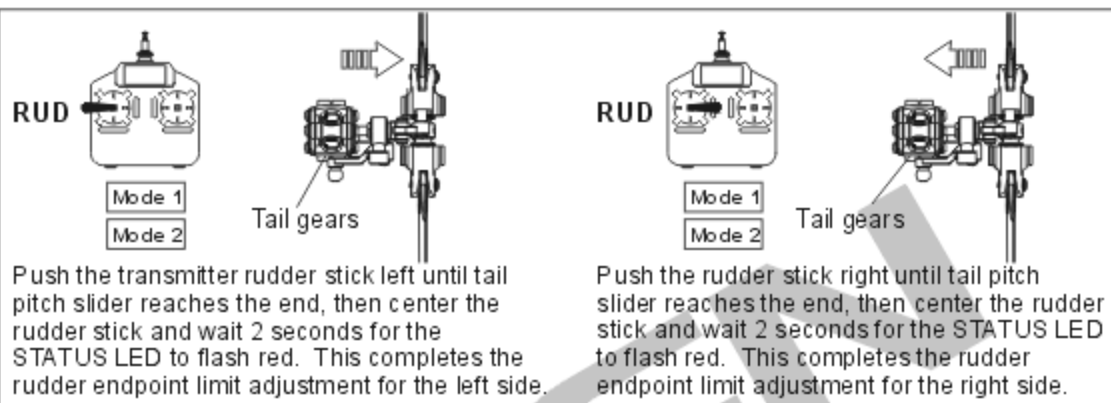

Flashing red LED indicates settings have been registered



endpoint limit settings

CAUTION

Rudder travel limit setting lower than 50% will not be registered. Mechanical fix (moving link ball closer to center of servo horn) is needed for excessive servo travel when LIMIT function is below 50%.

Step 6 : Helicopter size and DELAY settings

This setting includes two functions :

- (1) For small helicopters such as T-Rex 250/450, set this setting to small helicopter (STATUS LED red). For larger helicopters such as T-Rex 500/600/700 set this setting to large helicopter (STATUS LED green).

Green LED: suitable for larger helicopters such as T-REX 500/600/700
Red LED: suitable for smaller helicopter such as T-REX 250/450

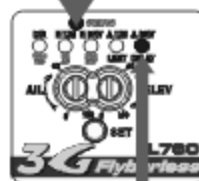

Helicopter size selection and servo delay settings

Select by moving the rudder stick left and right



- (2) The DELAY function is utilized when slower rudder servo causes tail hunting (wagging). This can be observed after a hovering pirouette comes to a stop. If tail hunting occurs, gradually increase DELAY value to eliminate it. For best performance, DELAY value should be kept as low as possible without tail hunting.

Setup method : Press and hold the SET button for 2 seconds to enter the setup mode, then press the SET button to select DELAY setup mode, as indicated by the lighting of DELAY LED. The choice of small or large helicopter is done by moving the transmitter rudder stick left or right while observing the color of the STATUS LED. For small helicopters STATUS LED will be red, and large helicopter will be green. The amount of servo delay is set by how far you push the rudder stick, followed by pushing the SET button.



0% when DELAY LED begins flashing

Gradually move the transmitter rudder stick until DELAY LED begins to flash, the delay value is 0% at this point.

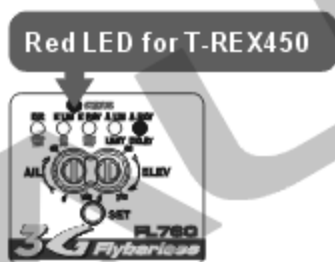
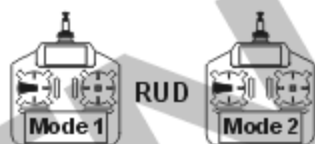

Continue to move the rudder stick until desired delay value is needed, then press the SET button to register the setting. Maximum is 100% delay, with rudder stick pushed to the end.



Step 7 : Sensitivity Adjustment

For radio with built in gyro gain settings, gain can be adjusted directly. For example, 50%-100% setting on the radio translates to 0%-100% gain in the heading lock mode; 50%-0% setting on the radio translates to 0%-100% gain in the normal (non-heading) lock mode.

Actual gain value differs amongst servos and helicopters. The goal is to find the maximum gain without tail hunting. This can only be done through actual flight tests.

The recommended starting point for transmitter's gyro gain setting should be 70~80% for hovering, 60~70% for idle-up. Value should be tuned under actual flight conditions by increasing to the maximum gain without tail hunting.



For radios (IE Futaba) using 0-100% as heading lock gain scales, the recommended gain setting is 30% to 35%. For radio that uses the 50 -100% scale (such as JR and Hitec), the recommended gain setting is 70% to 75%.

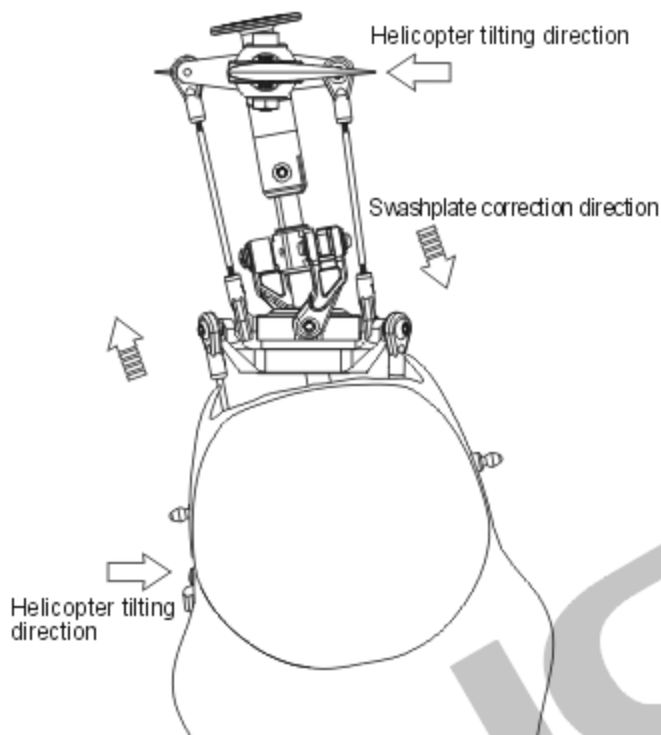

Step 5

Tilt the helicopter to the right and swashplate should tilt left to compensate. If reversed, perform the flybarless initial setup again and adjust the aileron reverse setting (Refer to P.12: A:REV setup)

Step 6

With throttle stick all the way up (and down), and cyclic stick all the way left/right and up/down, check for any binding on the swashplate. If binding occurs, perform the flybarless initial setup again and adjust the endpoint limits.

Step 7

Check the center of gravity (CG) and adjust component placement until CG point is right on the main shaft of the helicopter.

Step 8

With all above steps checked, restart the system and begin flight test.

HELICOPTER CG CHECK PROCEDURE

With a full fuel tank, hold the helicopter as shown. Once the helicopter stops rotating, the helicopter's CG can be seen at where the head is pointing relative to the main shaft.

Helicopter head should be level with main shaft, or slightly lower than the main shaft to ensure the center of gravity is maintained during flight.

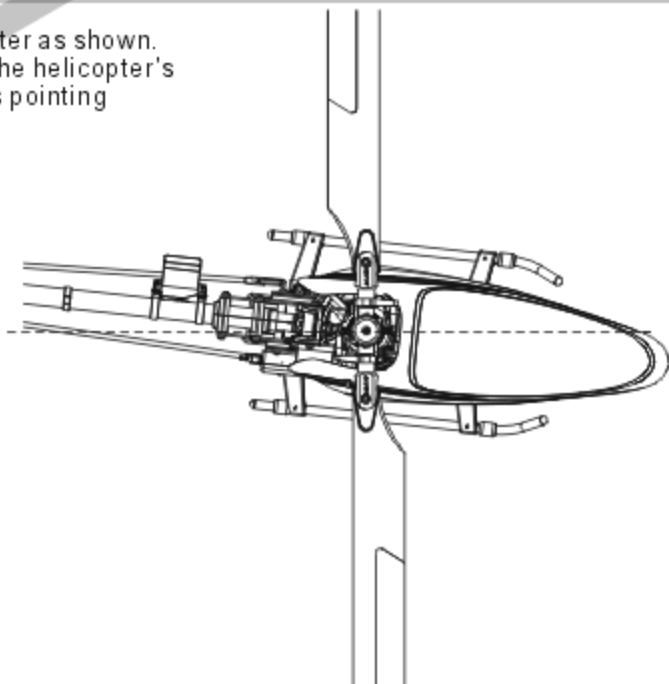

Step 1

This procedure is best performed on soft surfaces such as grass. The use of rubber skid stopper is recommended on hard surface to prevent vibration feedback from the ground to flybarless sensors, resulting in over-corrections.

Rubber skid stoppers installed

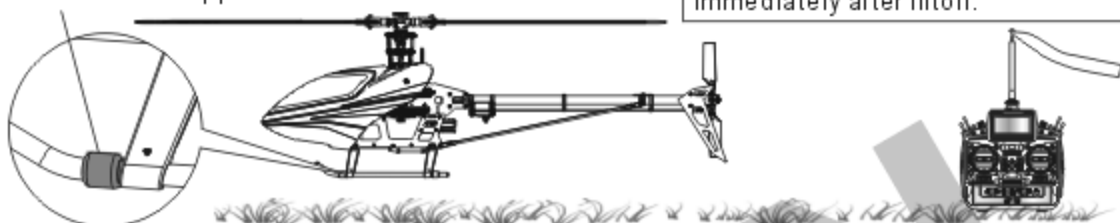
**CAUTION**

If swashplate should tilt prior to lift off, do not try to manually trim the swashplate level. This is due to vibration feedback to the sensor, and will disappear once helicopter lifts off the ground. If manual trim is applied, helicopter will tilt immediately after liftoff.

Step 2

With the helicopter hovering, observe for any rapid left/right or forward/aft oscillations. If forward/aft oscillation is observed, land the helicopter, turn the ELE gain dial counterclockwise gradually, and test again. Do this until oscillation disappears.

Set the dial to 12 o'clock position as starting point

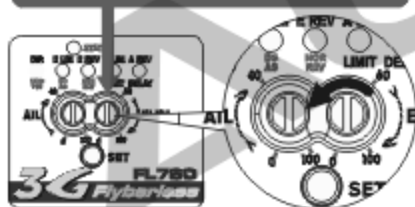
Elevator gain adjustment dial

Decrease ELE gain



Forward/back oscillation



If left/right oscillation is observed, land the helicopter, turn the AIL gain dial counterclockwise gradually, and test again. Do this until oscillation disappears.

Set the dial to 12 o'clock position as starting point

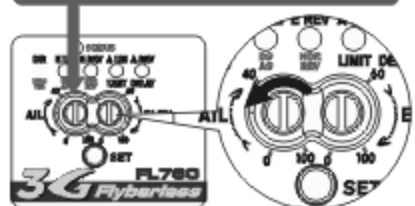
Aileron gain adjustment dial

Decrease AIL gain



Left/right oscillation



FORWARD STRAIGHT LINE FLIGHT

Put the helicopter into fast forward flight from hovering. If similar oscillation is observed, reduce the elevator gyro gain. If the helicopter pitches up, or responds slowly, increase the elevator gyro gain. Repeat test until the oscillation is eliminated. Similar method is used for aileron gyro gain.

After gyro gain adjustments are completed, the helicopter cyclic rate can be tuned using transmitter's swash AIL and ELE mixing ratio. Higher the percentage, faster the roll/flip rate. Exponential can also be added on the transmitter to soften the sensitivity for stable hover.

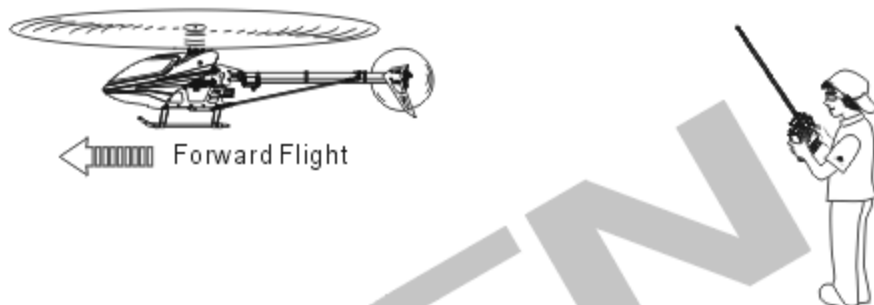

11 - SETUP EXAMPLES

ALIGN

Using Futaba 12ZH transmitter as an example

	with emphasis on stability	with emphasis on agility
Main blade pitch Settings (Collective Pitch Settings)	Main blade pitch : 12° swash pitch : 40%	Main blade pitch : 14° swash pitch : 50%
Cyclic pitch settings (Adjust while in DIR mode using AIL/ELE swash AFR)	Cyclic Pitch 9° swash Aileron : 45% Elevator : 45%	Cyclic Pitch 11° swash Aileron : 55% Elevator : 55%
Aileron and Elevator swashplate mixing ratio settings	swash Aileron : ≤ 45% Elevator : ≤ 45%	swash Aileron : ≤ 55% Elevator : ≤ 55%
Aileron and Elevator gyro gain settings	12 o'clock direction (50%)	11 o'clock direction (40%)

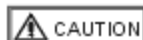

While in DIR setup mode, the transmitter's CCPM swash mixing values for aileron and elevator represent CYCLIC pitch values. These values affect the cyclic roll rates on the aileron and elevator in flying condition. Higher values translate to faster cyclic roll rates. If cyclic roll rate is not improved with increased swash mixing values, this is due to insufficient cyclic pitch. When this happens, cyclic pitch can be increased through the flybarless setup procedure. Maximum cyclic pitch should be limited at 11 degrees.

	Problem	Cause	Solution
Blade Tracking	Tracking is Off	Pitch linkage rods are not even length	Adjust length of pitch linkage rods (A)
Hover	Headspeed too low	Excessive pitch	Adjust pitch linkage rods (A) to reduce pitch by 4 to 5 degrees.
		Hovering throttle curve is too low	Increase throttle curve at hovering point on transmitter (around 65%~70%)
	Headspeed too high	Not enough pitch	Adjust pitch linkage rods (A) to increase pitch by 4 to 5 degrees.
		Hovering throttle curve is too high	Decrease throttle curve at hovering point on transmitter (around 65%~70%)
Rudder Response	Drifting of tail occurs during hovering, or delay of rudder response when centering rudder stick.	Rudder neutral point improperly set	Reset rudder neutral point
		Rudder gyro gain too low	Increase rudder gyro gain
	Tail oscillates (hunting, or wags) at hover or full throttle	Rudder gyro gain too high	Reduce rudder gyro gain
Oscillation during flight	Forward/aft oscillation when elevator is applied	Elevator gyro gain too high.	Turn the ELE gain dial on control box counterclockwise, 10 degrees at a time until oscillation is eliminated.
	Helicopter front bobbles (nods) during forward flight.	Worn servo, or slack in control links	Replace servo, ball link, or linkage balls.
	Left/right oscillation when aileron is applied	Aileron gyro gain too high	Turn the AIL gain dial on control box counterclockwise, 10 degrees at a time until oscillation is eliminated.
		Worn servo, or slack in control links	Replace servo, ball link, or linkage balls.
Drifting during flight	Elevator input causes helicopter to drift	Elevator gyro gain too low	Turn the ELE gain dial on control box clockwise, 10 degrees at a time until drifting is eliminated.
	Helicopter pitches up during forward flight		
	Aileron input causes helicopter to drift	Aileron gyro gain too low	Turn the AIL gain dial on control box clockwise, 10 degrees at a time until drifting is eliminated.
Control Response	Slow Forward/Aft/Left/Right input response	Roll rate too low	Increase the swashplate AFR in transmitter
		Roll rate still slow after swash afr adjustment, cyclic pitch too low	Go back through the DIR setup procedure and increase the cyclic pitch.
	Sensitive Forward/Aft/Left/Right input response	Roll rate too high	Decrease the swashplate AFR in transmitter
		Roll rate still too fast after swash afr adjustment, cyclic pitch too high	Go back through the DIR setup procedure and decrease the cyclic pitch.

If above solution does not resolve your issues, please check with experienced pilots or contact your Align dealer.

- Q&A 1 Pitches up during fast forward flight.**
 (1) Elevator gyro gain too low, increase the elevator gain by gradually turning the ELE dial clockwise.
 (2) Elevator trim not centered. Check if helicopter is tilting backwards during hover.
- Q&A 2 Insufficient gain during flight, but increasing gain results in oscillation.**
 (1) Check and resolve possible mechanical vibration from helicopter.
 (2) Use softer sensor mounting foam, or double up the stock sensor foam.
 (3) Relocate the sensor to location less prone to vibration.
- Q&A 3 Drifting during 3D maneuvers.**
 (1) Increase AIL and ELE gain by turning both dials clockwise.
 (2) Check if cyclic servos are too slow (minimum 0.09sec / 60 degrees)
- Q&A 4 Unstable hover, control inputs are too sensitive.**
 Decrease the aileron and elevator ATV (AFR) value on the transmitter. For CCPM machines, decrease swashplate mixing percentage on the transmitter. In addition, exponential can be added to aileron and elevator channels.
- Q&A 5 After increasing the ATV (AFR) of aileron and elevator, 3D roll rates are still not enough.**
 Go back through the DIR setup procedure and use larger cyclic pitch.
- Q&A 6 Helicopter oscillates after fast forward flight or after tumbles.**
 (1) Gradually reduce both AIL and ELE gain by turning them counterclockwise, 10 degrees at a time.
 (2) Use harder head dampener.
- Q&A 7 While in flybarless setup mode, unable to complete ELE/AIL endpoint and reverse settings.**
 Disable all trims/subtrims on the transmitter.
- Q&A 8 Incorrect CCPM mixing after initial flybarless setup.**
 (1) Trim/subtrims not zeroed out on transmitter.
 (2) After any trim adjustments are done on transmitter, the initial flybarless setup procedure need to be performed again.
- Q&A 9 3G flybarless system unable to power up.**
 (1) Check proper voltage source.
 (2) Check AIL/ELE/PIT connections between flybarless control unit and receiver.
 (3) Check for connection between flybarless control unit and sensor.
- Q&A 10 3G flybarless system powers up with LED flashing, but swashplate did not jump 3 times, pitch is locked, unable to complete the initialization process.**
 (1) Possible movement during initialization process. Make sure helicopter is absolutely stationary.
 (2) If STATUS LED flashes red, check the connection between flybarless controller and sensor.
- Q&A 11 I noticed swashplate tilts slightly at extreme pitch due to servo interactions, should I make efforts to level it out?**
 No. Level the swashplate at 0 degrees using subtrims ONLY in DIR setup mode. End point swashplate interactions are automatically compensated by the 3G system while in flight.
- Q&A 12 I want to trim the heli differently for different flight conditions.**
 After initial DIR setup is complete, the trim tabs on your TX can be used to trim the heli. Use your TX's flight condition functions to have multiple trim settings. Do not adjust the subtrim unless you are in the DIR setup mode!
- Q&A 13 What adjustments can I make on the transmitter after the DIR setup has been completed?**
 You can adjust the trim tabs, dual rates, exponential, collective pitch, and ail/elev swash AFR (for roll rate). Again do NOT adjust the subtrims unless followed by repeating of DIR setup steps.
- Q&A 14 During step 5 of DIR setup mode, only aileron swash mixing was mentioned. Should I set elevator swash mixing as well?**
 No. The 3G system automatically calculates a cyclic ring based on the aileron swash mix percentage. Setting of elevator swash mix has no effect on the 3G system. Set the cyclic pitch by the aileron swash mix & just use the same value for elevator.

14 · SPECIFICATIONS

Operating voltage range	DC 3V~8.4V	Operating humidity	0%~95%
Operating current consumption	<80mA @ 4.8V	Dimension	Control unit : 42x26.5x14.5mm
Rotational detection rate	±300°/sec		Sensor : 22.3x21.7x14mm
Rudder yaw detection rate	±500°/sec	Weight	Control unit : 16g
Sensor resolution	12bit		Sensor : 9g
Operating temperature	-20°C~65°C	●RoHS certification stamp	

www.align.com.tw

www.align.com.tw

www.align.com.tw

ALIGN